

# Slayer Steam X

Professional Espresso Machine Series

2-Group and 3-Group Models

USER MANUAL 1.0  
FIRST DRAFT JANUARY 19, 2018

#### COPYRIGHT INFO

COPYRIGHT © 2016 BY SEATTLE ESPRESSO MACHINE CORPORATION

ALL RIGHTS RESERVED. NO PART OF THIS PUBLICATION MAY BE REPRODUCED, DISTRIBUTED, OR TRANSMITTED IN ANY FORM OR BY ANY MEANS WITHOUT THE PRIOR WRITTEN PERMISSION OF THE PUBLISHER, EXCEPT IN THE CASE OF NONCOMMERCIAL USES PERMITTED BY COPYRIGHT LAW. FOR PERMISSION REQUESTS, CONTACT THE PUBLISHER.

SEATTLE ESPRESSO MACHINE CORPORATION  
6133 6TH AVENUE SOUTH  
SEATTLE, WASHINGTON, USA 98108

SLAYERESPRESSO.COM

#### TERMS AND CONDITIONS

SLAYER MAKES NO REPRESENTATIONS OR WARRANTIES WITH RESPECT TO THE CONTENTS OF THIS PUBLICATION. INFORMATION CONTAINED HEREIN IS SUBJECT TO CHANGE WITHOUT NOTICE. EVERY PRECAUTION HAS BEEN TAKEN IN THE PREPARATION OF THIS MANUAL; NEVERTHELESS, SLAYER ASSUMES NO RESPONSIBILITY FOR ERRORS OR OMISSIONS OR ANY DAMAGES RESULTING FROM THE USE OF THIS INFORMATION.

READ THIS MANUAL COMPLETELY BEFORE INSTALLING AND OPERATING YOUR SLAYER STEAM X ESPRESSO MACHINE. INCORRECT INSTALLATION AND OPERATION MAY RESULT IN DAMAGE TO THE EQUIPMENT, PERSONAL INJURY, OR EVEN DEATH. DISREGARDING THE INSTRUCTIONS CONTAINED HEREIN INDEMNIFIES SLAYER FROM ALL RESULTING DAMAGES AND MAY VOID THE EQUIPMENT WARRANTY.

FOR ADDITIONAL SAFETY PRECAUTIONS, SEE THE SAFETY ADVISORY ON PAGE #7.

# Table of Contents

1	Slayer Steam X	
3	Table of Contents	
4	Welcome	
5	Resources	
6	Warranty Information	
7	Safety Advisory	
8	Water Treatment Requirements	
9	Recommended Tools & Accessories	
10	Installation	
11	Step 1: Prepare Site	
12	Step 2: Unpack Equipment	
13	Step 3: Connect Plumbing	
14	Step 4: Connect Power	
15	Step 5: Fill Tanks	
15	Step 6: Turn On Elements	
16	Using Slayer Steam X	
17	Espresso Basics	
20	Factory Settings	
21	The Barista Dashboard™	
24	Prepare Espresso	
25	Steam Milk	
26	Use Hot Water Tap	
26	Adjust Hot Water Temperature	
26	Adjust Drain Tray	
27	Adjust Brew Pump Pressure	
27	Adjust Brew Volumes	
28	Adjust Brew Tank Temperatures	
28	Adjust Steam Tank Pressure	
29	Adjust Hot Water Dose	
29	Adjust Hot Water Temperature	
30	Other Menu Actions	
33	Cleaning & Preventative Maintenance	
34	Clean Your Machine	
34	Clean the Steam Wands	
35	General Grouphead Care	
35	Backflush the Groupheads	
36	Backflush the Groupheads, continued	
37	Fast Clean	
38	Part Diagrams	

# Welcome

Established in 1997 the Slayer story catalog of hand crafted machines continues to grow and meet the demands of Slayer users. The second machine in the new Steam series, Steam X celebrates what you have come to love in Slayer, exceptional design, durability and consistent results for high volume cafes. When the details matter, this back to basics model is a barflow dream, with professional features that streamline beverage production with a moderate entry into ownership.

Jason Prefontaine founded Slayer when he had an idea for revolutionizing espresso, but that was just the beginning. The Steam series is the result of his continued commitment to Make Coffee Better™. Expanding the Slayer portfolio of professional equipment, we now turn to the milk-dominated world of high-volume coffee business with the same inventive approach that we first took to espresso.

Slayer Steam X lever activated, dual volumetrics in each group head and numerous time-saving features. A must have model for cafe chains that are looking to scale cup consistency and guest engagement in high volume cafes.

Research and Development is led by Jason Prefontaine, Chris Flechtner, and the Experience Team, Steam is the result of a creative collaboration between this dedicated group and many talented friends in the industry. When industry professionals talk, Slayer listens with our most powerful tool being the advice of professional baristas, coffee people and technicians.

# Resources

For quick installation, see the QUICK START GUIDE that was included with your machine upon delivery located in the clear packing envelope taped on the lid of your crate.

For everything else, contact your authorized Slayer reseller or the appropriate party listed below.

## TECHNICAL SUPPORT & PARTS

[support@slayerespresso.com](mailto:support@slayerespresso.com)

## SALES

[sales@slayerespresso.com](mailto:sales@slayerespresso.com)

## MARKETING

[marketing@slayerespresso.com](mailto:marketing@slayerespresso.com)

## TRAINING & EDUCATION

[training@slayerespresso.com](mailto:training@slayerespresso.com)

## ORDERS

[orders@slayerespresso.com](mailto:orders@slayerespresso.com)

## SHIPPING

[shipping@slayerespresso.com](mailto:shipping@slayerespresso.com)

## Warranty Information

Slayer provides a 15-month (fifteen month) warranty on all equipment and parts, beginning at the date of shipment from the Seattle headquarters. All equipment and parts are warranted to be free from defect in material or workmanship. Unless otherwise specified in writing, this warranty covers materials only (e.g. equipment, parts) and excludes labor, shipping, and any other costs.

This warranty does not cover accidental damage to equipment, abuse of equipment, or improper use of equipment. "Improper use" includes, but is not limited to, the operation of a machine with inadequately treated water and/or the operation of a machine with inadequate water supply. Any and all damage resulting from inadequate water treatment is expressly excluded from the coverage of this warranty. Read "Water Treatment Requirements" on page #8 for information about water-related issues.

Damage resulting from improper installation of equipment is expressly excluded from this warranty.

Warranty coverage does not include parts that are subject to normal wear and tear, as determined by Slayer. These include, but are not limited to, shower screens, portafilter gaskets, expansion or anti-suction valves, and preventative maintenance parts. Warranty coverage excludes glass or plastic parts.

This warranty will immediately expire if you or a third party performs faulty maintenance, excessive use, or neglect of necessary service. This will include any instances in which, following the occurrence of a defect, you fail to immediately take all suitable measures to limit damage to the equipment and/or fail to provide Slayer with an opportunity to remedy the defect.

Slayer's sole responsibility and liability under the warranty set forth herein is limited to, in Slayer's sole discretion, repair or replacement of defective parts. Unless otherwise specified in writing, this excludes labor, shipping, and any other costs.

To the fullest extent permitted by applicable Washington State (USA) laws, Slayer's warranty set forth herein is limited to the original purchaser of the equipment. Slayer does not, directly or indirectly, offer any warranty to any other person, unless otherwise agreed in writing.

Except as expressly provided herein, all goods are provided to you as they are. Slayer disclaims all representations and warranties, whether expressed or implied, including warranties of title, non-infringement, merchantability, and fitness for a particular purpose.

Warranty claims must be authorized by a Slayer representative prior to repair or remedial action.

## Safety Advisory

This guide includes important instructions about safe espresso machine installation, operation, and maintenance. Read this manual completely before installing and operating your Slayer espresso machine. Incorrect installation and operation may result in damage to the equipment, personal injury, or even death. Disregarding the instructions contained herein indemnifies Slayer from all resulting damages and may void the machine's warranty.

Shipping is coordinated by the customer and performed by a third party. Slayer is not responsible for damage incurred during transport. Upon receiving your machine, carefully inspect all packaging, equipment, and accessories for visible damage. Photograph any visible damage and immediately contact your shipping company representative. Comply with shipping company regulations. Do not connect your machine to power, water, or drainage until all issues have been resolved or your Slayer representative or reseller instructs you to do so. Failure to resolve issues before using equipment may result in further damage or injury.

Installation should be performed by qualified personnel only and must comply with all regulations and requirements of the authorities in your area. If guidance is needed to safely install your machine, contact your Slayer representative or reseller.

It is critical that an appropriately-rated and grounded electrical plug is used to supply your machine with power. This is essential for the safe operation and use of the equipment. Contact your Slayer representative or reseller with questions about this requirement. If you are unsure about the safety of the electrical configuration, do not attempt to install your machine.

Your Slayer espresso machine should only be used for the functions it was designed to perform. Using your machine outside of its defined functionality – as it is described in the "Using Slayer" section on page #16 of this guide – may be a safety hazard, resulting in property damage, physical injury, or even death, and will immediately void the warranty.

Slayer espresso machines are electrical appliances that should be used in a safe manner appropriate to devices of their kind:

- **Do not** connect your Slayer espresso machine to electrical power through an extension cord. The machine must be directly connected to an appropriately- rated and grounded power source.
- **Do not** position the power cord in walkways or other high-traffic areas.
- Slayer espresso machines are designed to be used indoors. When using your machine outdoors, take precautionary measures to protect it from moisture, humidity, and other natural elements.
- **Before performing service on your machine, disconnect the power source.**

## Water Treatment Requirements

Improper water treatment is the most frequent cause of espresso machine damage. Water is complex and varies significantly between regions, so take great care to test the water quality at your location and adjust as necessary. Employ professional help to evaluate your water and administer treatments.

When evaluating water quality, the two most important factors to consider are calcium carbonate and chloride:

**Calcium Carbonate:** a dissolved mineral that determines the “hardness” or “softness” of water. The desirable range of hardness is 4-5 grains. Over time, calcium carbonate accumulates as a hard substance, called “scale”, and will inhibit the flow of water. Machines subjected to “harder” water (greater than 5 grains) will accumulate scale faster and require maintenance earlier.

**Chloride:** chlorine combined with an electron from a negatively charged ion. There are many types of chlorides, including calcium chloride, magnesium chloride, sodium chloride, etc. Chlorides produce salts that impart a strong taste, which alters the flavor of the espresso. Chlorides also encourage pitting corrosion, which causes damage to the machine.

Your water filtration company will create a treatment plan based on your water needs. Choose a filtration company that has solutions for addressing issues related to both calcium carbonate and chloride.

Common treatment options include carbon filtration, ion exchange, and reverse osmosis:

**Carbon Filtration:** a process by which water passes through the granular activated carbon, which attracts and retains many chemicals in the water that have an unpleasant color, taste or odor. Carbon filtration is necessary for all machines. For water with 4-5 grains of hardness, carbon filtration is likely the only necessary water treatment.

**Ion Exchange:** a process by which water passes through an ion exchange system, where undesirable mineral components are retained and more desirable substances such as sodium are released. An ion exchange system should be used

in combination with a carbon filtration system and is especially beneficial for water in the range of 6-9 grains of hardness. This system is relatively inexpensive and effective in removing inorganic substances. It does not, however, remove organic substances, such as bacteria.

**Reverse Osmosis with Blend-Back Valve (or Remineralized RO):** a process by which water is forced through a semi-permeable membrane with selective pore sizes at high pressure, then blended with the appropriate amount of desired minerals. Reverse osmosis may be a good solution for water in the range of 6-9 grains of hardness and is mandatory for water above 9 grains. When blending minerals with the filtered water, target a TDS (total dissolved solids) value of 75-125 ppm. Experiment with various TDS levels to determine what produces your preferred taste.

All Slayer espresso machines need to be connected to a carbon water filter to remove chlorine, sediments, odor, and undesirable tastes. This requirement is in addition to any other necessary water filtration systems.

Filtration requirements may vary seasonally. Water should be tested during each season to determine the best filtration plan. Once a filtration method has been selected, take note of the filter's peak capabilities. Contact the equipment vendor to inquire about the life expectancy of the filters, then schedule replacement and reinstallation accordingly.

**IMPORTANT:** Every time a new water filter is installed, thoroughly rinse the filter before attaching it to your machine or pump. Run water from the supply line through the filter and down a drain for at least 2 minutes. Skipping this step will cause damage to your machine. Damage to or failure of your machine due to inadequately treated water is not covered under warranty.

# Recommended Tools & Accessories

## BEVERAGE PREPARATION

- Espresso grinder
- Scale (must measure in 0.1-gram increments)
- Tamper (must have a 58-millimeter base diameter)
- Shot glasses
- Steaming pitcher
- Soft towels

## EQUIPMENT CARE & MAINTENANCE

- Allen keys
- crescent wrench
- flat-head screwdriver
- Grouphead brush
- Needle-nose pliers
- #2 Phillips-head screwdriver
- Pick or awl
- Pliers
- 9/16-inch socket wrench
- Adjustable wrench
- Approved espresso machine cleaner
- Approved espresso machine steam wand cleaner
- Non-abrasive surface cleaner
- Slayer lubricant
- Teflon tape

# Installation

Only qualified service personnel should install Slayer espresso machines. Incorrect installation may result in injury and/or damage to the equipment. Please read the “Safety Advisory” on page #7 before beginning installation.

Install your Slayer espresso machine with the following ordered steps:

- 11 Step 1: Prepare Site
- 12 Step 2: Unpack Equipment
- 13 Step 3: Connect Plumbing
- 14 Step 4: Connect Power
- 15 Step 5: Fill Tanks
- 15 Step 6: Turn On Elements

## Step 1: Prepare Site

Your installation site will require access to power, water, and drainage. Building regulations vary by region, so confirm local requirements before connecting your machine.

Using quality, treated water is essential to achieving the best possible results when preparing coffee and may also extend the life of your machine. Read "Water Treatment Requirements" on page #8 for information about avoiding and addressing water-related issues.

Your Slayer Steam X machine needs to be installed on a structure that is capable of supporting its weight, including the weight of the water, once filled:

### STEAM WITH ALL TANKS FILLED

2-group	100 kilograms (220 pounds)
3-group	140 kilograms (305 pounds)

Use the following diagrams to locate and drill holes in the counter for the power cords and plumbing lines. Note that electrical plugs vary in size and a larger hole may be required to accommodate the main power cord.

Optional: prepare two (2) or more identical block risers, each with a maximum height of 15 centimeters (6 inches) and capable of supporting 140 kilograms (305 pounds). The risers should be designed to elevate the machine approximately 15 centimeters (6 inches) above the counter without touching the drain tray or wing legs. Position the risers on the prepared counter, according to the following diagrams.

3-group

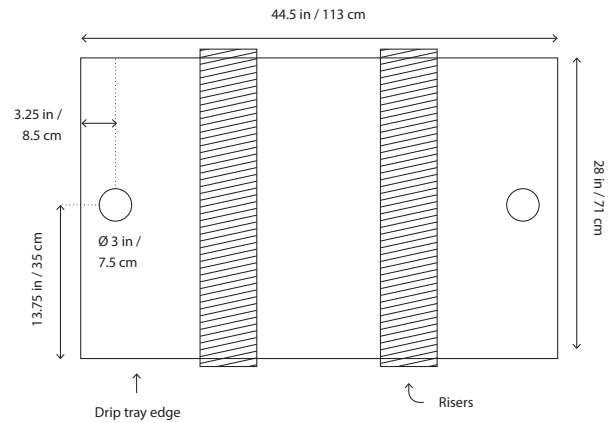

2-group

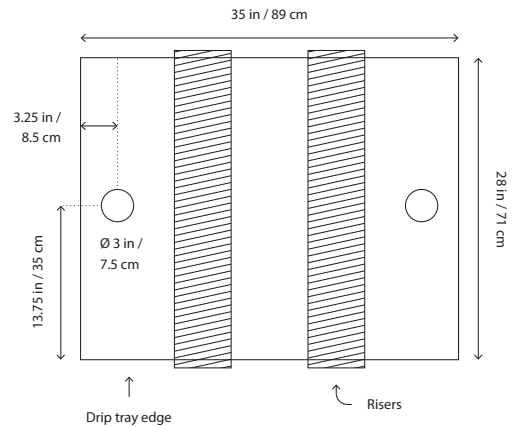

## Step 2: Unpack Equipment

Your Slayer Steam X machine will arrive in a lidded wooden crate, bolted to a pallet at the base. Unpack with the following steps. At least three (3) able-bodied people will be needed to lift your machine.

### INCLUDED PARTS

- Four (4) rubber feet

### REQUIRED TOOLS & SUPPLIES

- #2 Phillips-head screwdriver
- Knife or box cutter
- 9/16-inch socket wrench
- Optional: two (2) or more identical block risers with a maximum height of 15 centimeters (6 inches), capable of supporting 305 pounds (140 kilograms)

### PROCEDURE

1. Use a Phillips-head screwdriver to loosen and remove the eight (8) screws found along the lower edge of the crate, two (2) at each corner, then lift the crate from the pallet.
2. Remove the plastic sheet from the machine and identify all crate contents:
  - Slayer Steam X espresso machine
  - Attached power cords (2), plumbing lines (2), and drain hoses (2)
  - External rotary pump
  - Accessories box
3. Set aside the accessories box.
4. Locate the two (2) bolts and two (2) nuts that secure the pump to the pallet, then use a wrench to loosen and remove the nuts; set aside the pump.
5. Use a knife or box cutter to remove the banding from the machine body. To

protect the machine during installation, keep all other packing material in place.

6. Locate the four (4) bolts that are threaded into the two (2) wing legs, then use a 9/16-inch socket wrench to loosen and remove all bolts.
7. Pull the locking pins on both sides of the drain tray, one at a time, to move the drain tray to the highest position (if not already in the highest position); release the pins to set the tray height.
8. Employ the assistance of at least three people to lift the machine up and away from the crate base, minding the attached cords, lines, and hoses.

**Lift only from the chassis; do not handle the drain tray, cup rail, or any part of the wing legs. To protect yourself during this step, wear thick gloves or drape a small towel over each wrist and forearm.**

9. Suspend the machine with the wing channels located directly above the prepared counter holes. If using risers, lower the machine onto the risers. The risers should support the chassis without touching the drain tray.
10. Locate the four (4) rubber feet inside of the accessories box and install them on the wing legs. Later, adjust the feet individually to level the machine.
11. Remove the packing material from the attached cords, lines, and hoses, then run them through the wing channels and counter holes.
12. Lower the machine into the prepared position and remove all packing material.
13. Lift to remove the four (4) cup tray panels; set aside.

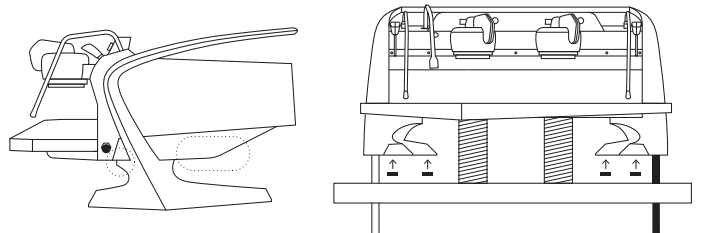

## Step 3: Connect Plumbing

Your Slayer Steam X machine will arrive with two (2) plumbing lines and two (2) drain hoses attached. One (1) additional plumbing line will arrive inside of the accessories box. A water treatment system is required, but not included. Read "Water Treatment Requirements" on page #8 for information about avoiding and addressing water-related issues.

### INCLUDED PARTS

- Two (2) drain hoses with an inside diameter of 5/8 inch (16 millimeters)
- One (1) 30 inch by 3/8 inch braided hose (in North America, includes 3/8-inch compression fitting)
- Two (2) 60 inch by 3/8 inch braided hoses, color-coded
- External rotary pump

### REQUIRED TOOLS & SUPPLIES

- Water treatment system (see page #8 for recommendations)
- Adjustable wrench

### PROCEDURE

1. Install your water treatment system according to the instructions provided by the manufacturer, then turn off the main water supply.

**Before use, all treatment systems should be flushed with water for at least two (2) minutes.**

2. Ensure that the machine is in position, with all cords, lines, and hoses running through the wing channels and counter holes (per previous steps).
3. Run the two (2) drain hoses to an open gravity drain, ensuring that the lines always slope downwards.

4. Locate the 30 inch by 3/8 inch braided hose inside of the accessories box and use it to connect the water treatment system to the external rotary pump, tightening with a wrench.
5. Locate the two (2) color-coded braided hoses, attached to the machine, and the color-coded connections on the pump.
6. Connect each hose to its color-matched connection on the pump, tightening with a wrench.

**Do not turn on the main water supply.**

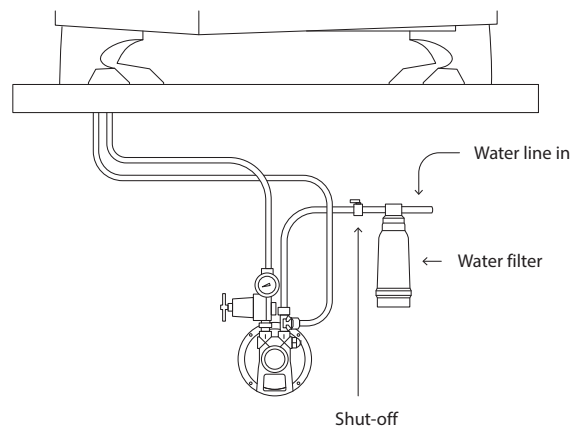

## Step 4: Connect Power

Your Slayer Steam X machine will ship with the power configuration requested at the time of purchase. In most cases, this will include a plug end on the power cord. If your machine does not include a plug, do not attempt to wire it yourself. Only an electrician or approved technician should wire the power cord into an appropriately-rated plug end.

### INCLUDED PARTS

- External rotary pump

### PROCEDURE

1. Ensure that both steam actuators are in the "off" position and the drain hoses and water lines are connected (per previous steps).
2. Insert the main power plug into an appropriately-rated and grounded receptacle
3. Locate the quick connect plug, found on one of the electrical cords that extends from your machine, and insert it into the matching plug unit on the pump motor.

**Do not move the steam actuators to the "on" position.**  
**Do not turn on the main water supply.**

Main power



Quick connect plug

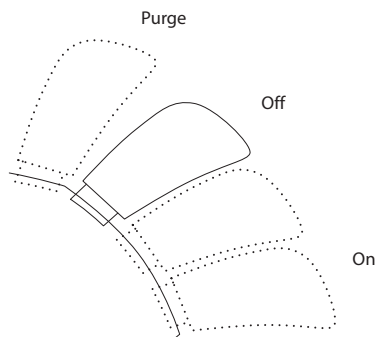

## Step 5: Fill Tanks

### PROCEDURE

1. Ensure that both steam actuators are in the "off" position, the drain hoses and water lines are connected, and the cup tray panels have been removed (per previous steps).
2. Turn on the main water supply.
3. Check the inside of the machine for leaks or collected water.
4. Turn on the power to your machine by pressing the power switch; the steam tank will begin to fill.

**Filling will take 1-2 minutes and is complete when the pump motor ceases to work and a "click" is heard.**

5. Wait until the steam tank has filled completely, then fill the groupheads by moving the brew actuators left, to the "on" position, until water begins to flow.

**Factory settings for the volumetrics are set (reference Factory Settings on page #20). You may need to repeat this step multiple times, until water begins to flow.**

6. Move the brew actuators right, to the "off" position.
7. Activate the electronics by pressing any one of the jog wheels on the Barista Dashboard.

**Do not move the steam actuators to the "on" position.  
Do not engage the white heating element breaker.**

## Step 6: Turn On Elements

### PROCEDURE

1. Ensure that both steam actuators are in the "off" position, the cup tray panels have been removed, and the tanks have filled completely (per previous steps).
2. Turn on the heating elements by moving the heating element breaker left, to the "on" position.

**Do not move the steam actuators to the "on" position.**

3. Wait until the machine has heated fully, then move one of the steam actuators down, to the "on" position. If steam is produced, proceed to the next step. If no steam is produced, wait several minutes before repeating this step.
4. Check the inside of the machine for leaks or collected water.

**The anti-suction valve on the steam tank may sputter and release small drops of water when first building pressure. During your inspection, check for large pools or steady streams of water.**

5. Install the four (4) cup tray panels.

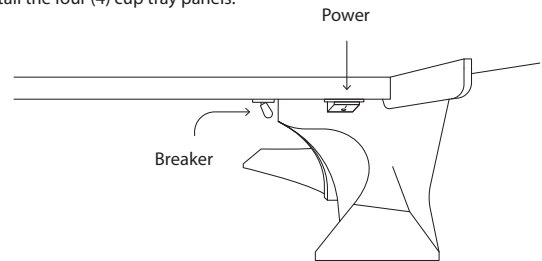

# Using Slayer Steam X

Your new machine features sophisticated technologies that are designed to improve numerous aspects of coffee beverage production. These innovations will promote efficiency, accuracy, and comfort on every bar where Slayer Steam X is found. Whether this is your first

espresso machine or the latest in a long career, our instructions should serve as a helpful baseline for getting the most out of Steam X.

We can't wait to see what you do with it.

## Contents

17	Espresso Basics	29	Adjust Hot Water Temperature
20	Slayer Steam X Factory Settings	30	Other Menu Options
21	The Barista Dashboard™		
24	Prepare Espresso		
25	Steam Milk		
26	Use Hot Water Tap		
26	Adjust Drain Tray		
27	Adjust Brew Pump Pressure		
27	Adjust Shot Volumes		
28	Adjust Brew Tank Temperature		
28	Adjust Steam Tank Pressure		
29	Adjust Hot Water Dose		

## Espresso Basics

Coffee “beans” are the seeds from berry-like fruits that grow on shrubs in equatorial regions. After picking and processing, the beans are roasted, ground, and dissolved in water to yield a coffee beverage.

Brewing espresso is a unique method of coffee extraction in which water is added to ground coffee under intense pressure. As a result, the beverage, when compared to filter coffee (e.g. pour-over, immersion), contains a higher concentration of dissolved coffee, feels heavier in the mouth, and asserts stronger flavor.

The espresso machine is the preferred equipment for preparing espresso. Therein, coffee is secured, water is heated, pressure is applied, filtration occurs, and the beverage is dispensed. The entire process takes less than one (1) minute.

Many variables affect espresso extraction and therefore require the attention of the barista. Consider the following generalizations and guidelines when preparing espresso.

### COFFEE ORIGIN

Coffee plants are cultivated around the world in equatorial regions that have varying climates and growing conditions. Every location – country, locale, farm, and lot – produces coffee with distinct characteristics that contribute to discernible differences in beverage flavor. Slayer Steam X is well-suited for preparing coffee from any single origin, as well as blends of coffees from varying origins.

### PLANT VARIETY

Like other fruits (e.g. apples, oranges), coffee beans may come from one of many varieties of the same plant. Common varieties include Typica, Bourbon, Heirloom, and Caturra, among others. Every variety produces coffee with distinct characteristics that contribute to discernible differences in beverage flavor.

### PROCESSING METHOD

There are many unique processes by which coffee seeds may be separated from the fruit containing them. Every process produces coffee with distinct characteristics that contribute to discernible differences in beverage flavor. Note these examples:

- **“Washed” process:** increased acidity, enhanced flavor clarity, clean body
- **“Natural” process:** fruit-forward flavor, full body
- **“Pulped natural”, “semi-washed”, and “honey” processes:** borrowed characteristics from washed and natural processes

### GREEN COFFEE FRESHNESS

After it has been picked and processed, green (i.e. un-roasted) coffee has a considerable shelf life. However, the potential quality of coffee beverages deteriorates with the age of the green coffee. For best results, buy roasted coffee from a trustworthy supplier that guarantees the freshness of its green coffee.

### ROAST PROFILE

Roasting makes the dense, green coffee bean porous and soluble and is the first step in preparing coffee for extraction. Coffee may be roasted to varying degrees by a variety of technologies, each producing coffee with distinct characteristics that contribute to discernible differences in beverage flavor.

Generally, the flavor of espresso prepared from light-roasted coffee will more closely resemble the characteristics of its origin, variety, and processing method (e.g. “bright”, “fruity”, etc.). Conversely, the flavor of espresso prepared from dark-roasted coffee will more closely resemble the characteristics of the roasting process (e.g. “smoky”). Typically over developed roast profiles do not exhibit the full potential of your machine, nor the flavorful complexity of your coffee.

#### ROASTED COFFEE FRESHNESS

After roasting, coffee beans are increasingly vulnerable to deterioration. Preserve freshness by storing in a sealed container in a cool, dark area. Ideally, use a container that allows the outward flow of gas, which coffee releases as it ages, but prevents the inward flow of oxygen. Espresso is generally most flavorful when prepared with coffee that has “rested” for at least two (2) days after roasting but has not exceeded three (3) weeks. These guidelines are especially important for dark-roasted coffee, which deteriorates faster than light-roasted coffee.

#### GROUND PARTICLE SIZE

Preparing espresso requires finely-ground coffee and a professional grinder. When setting up your grinder, target a setting that achieves the recommended beverage yield with the recommended dose weight in the recommended brew time. Continue reading for recommendations regarding these brewing parameters. Adjust grind as necessary, noting these rules:

##### **Finer grind setting** (smaller particles):

- Longer extraction time
- Enhanced body
- Reduced clarity

Recommended when espresso tastes sour, feels thin, extracts quickly, or has no crema.

##### **Coarser grind setting** (larger particles):

- Shorter extraction time
- Reduced body
- Enhanced clarity

Recommended when espresso tastes bitter, feels muddy, or extracts slowly.

#### DOSE WEIGHT

Dose weight refers to the amount of ground coffee used for a serving of espresso. When considered alongside the beverage yield, dose weight is part of the brew ratio, which correlates with the perceived strength of the espresso and influences the extraction process. Slayer recommends using a scale to measure 18-21 grams of ground coffee per espresso serving. Begin with 18 grams, then adjust dose weight as necessary, noting these rules:

##### **Larger coffee dose** (more weight):

- Increased flavor intensity
- Longer extraction time

Recommended when espresso tastes sour, feels thin, extracts quickly, or has no crema.

##### **Smaller coffee dose** (less weight):

- Decreased flavor intensity
- Shorter extraction time

Recommended when espresso tastes bitter, feels muddy, or extracts slowly.

#### BED DEPTH

Tamping ground coffee is essential to forming a puck through which water will evenly flow. Instead of tamping to a specific pressure (e.g., 30 pounds), Slayer recommends tamping to a specific depth in order to achieve the adequate headspace between the coffee puck and the shower screen. To ensure consistent results, target a tamp depth that levels the top of the tamper piston with the top of the portafilter basket (approximately 1 centimeter).

#### WATER TEMPERATURE

At the factory, the brew tank temperature is set to 93° C (200° F). Coffee is best brewed with water heated to 92-95° C (195-205° F).

Begin with the factory setting, then adjust the temperature as necessary, noting these rules:

##### **Higher temperature:**

- Increased extraction rate
- Enhanced acidity

Recommended when espresso tastes sour.

##### **Lower temperature:**

- Decreased extraction rate
- Reduced acidity

Recommended when espresso tastes bitter.

To adjust the brew temperature, see instructions under Using Slayer > Adjust Brew Temperature on page #26.

#### WATER PRESSURE

At the factory, the brew pump pressure is set to 9 bar. Generally, espresso is best brewed with water pressurized to 6-10 bar. More dense coffees (such as those grown at a higher elevation, processed with the “washed” method, and/or roasted light) may endure higher pressure, while less dense coffees (such as those grown at a lower elevation, processed with the “natural” method, and/or roasted medium-to-dark) prefer lower pressure.

To adjust the brew pump pressure, see instructions under “Using Slayer > Adjust Brew Pump Pressure” on page #27.

#### BEVERAGE YIELD

Beverage yield refers to the weight or volume of a serving of espresso. When considered alongside the dose weight, beverage yield is part of the brew ratio, which correlates with the perceived strength of the espresso and influences the extraction process. Slayer recommends using a scale or graduated shot glasses to measure 25-40 grams or 1.0-1.5 fluid ounces of espresso per serving. Begin with 35 grams or 1.25 fluid ounces, then adjust beverage yield as necessary, noting these rules:

##### **Larger yield** (more weight or volume):

- Decreased flavor intensity
- Longer extraction time

Recommended when espresso lacks clarity.

##### **Smaller yield** (less weight or volume):

- Increased flavor intensity
- Longer extraction time

Recommended when espresso lacks body.

#### BREW TIME

Brew time refers to the total duration of extraction. Begin with 25 seconds, then adjust brew time as necessary, noting these rules:

##### **Longer brew time:**

- Higher extraction yield

Recommended when espresso tastes sour.

##### **Shorter brew time:**

- Lower extraction yield

Recommended when espresso tastes bitter.

## Slayer Steam X Factory Settings

---

### SLAYER STEAM X FACTORY SETTINGS

---

Brew Tank Temperature	93° C (200° F)
Brew Pump Pressure	9 bar
Steam X Tank Pressure	1.7 bar
Volumetrics Dose 1/Dose 2	30/ 60

---

## The Barista Dashboard™

Slayer Steam X is equipped with a digital interface that displays the essential functions of the machine. Through the Barista Dashboard™, you have access to brewing parameters, advanced operating settings, and more.

### BASICS OF NAVIGATION

- Menus, settings, and queries display in rectangular screens, located directly above each grouphead.
- Jog wheels, located to the right of each screen, are used to enter menus, cycle options, make selections, and adjust settings. These actions are accomplished by pressing in or rotating the jog wheel.
- During the initial setup, select the item to change, choose to save across multiple groups if applicable, then scroll to the next menu setting until setup is complete.
- The menu layout is circular; after cycling through the end of the menu options, the first menu option will reappear.

**Protip: At any time, you may move the grouphead actuator left/right to quickly save/exit the menu.**

### GETTING STARTED

The left group screen is the main menu for all machine adjustments. Groups 2 and 3 (if applicable) have limited menus affecting only basic brewing parameters. While the machine is idle, the left group screen will display up to four (4) units of information: [add photo]

- **Brew temperature** ("Temp") reading, displayed in tenth-degree (0.1-degree) increments in Fahrenheit or Celsius.
- **Brew time** ("Time") for the previous extraction, displayed in tenth-second (0.1-second) increments. At the beginning of each extraction, the timer will automatically reset and begin counting up from zero (0). At the end of each extraction, the timer will automatically stop and will remain visible until the next

extraction begins.

- **Brew weight** ("WT") for the previous extraction, measured by a flow meter and displayed in tenth-gram (0.1-gram) increments. When a scale is not in use, weight will be displayed as an approximation based on readings from the flow meter.
- **Steam tank pressure** ("Stm") reading, displayed in 0.1-bar increments.

The screen that corresponds to the leftmost grouphead will display two (2) additional units of information:

- **Heating element activity**, represented by a colon (":"). When a brew tank is being heated, the colon will flash near the brew temperature reading on the corresponding screen.
- **Steam tank fill status**, represented by an upward-facing arrow. When the steam tank is being filled, the arrow will appear next to the steam tank pressure reading.

### MENU OPTIONS

The first level of navigation is the Barista Menu, which contains the options listed below. The screen will display as shown.

#### Option 1: Brew Volume

- Volumetric extraction setting, based on readings from flow meter
- Minimum setting: 10.0 grams  
Maximum setting: 99.9 grams  
Adjustable in tenth-gram (0.1-gram) increments

To adjust the brew volume, see instructions under Using Slayer > Adjust Brew Volume on page #27.

#### Option 2: Brew Temperature

- Brew tank temperature setting, measured in real-time at each grouphead and displayed in degrees Fahrenheit or Celsius, depending on saved preference.

- Minimum setting: 82° C (180° F)  
Maximum setting: 97° C (206° F)  
Adjustable in tenth-degree (0.1-degree) increments

To adjust the brew temperature, see instructions under Using Slayer > Adjust Brew Tank Temperature on page #28.

#### Option 3: Steam Tank Pressure

- Steam tank pressure setting, measured and displayed in bar units
- Minimum setting: 0.8 bar  
Maximum setting: 1.7 bar  
Adjustable in tenth-bar (0.1-bar) increments

To adjust the steam tank pressure, see instructions under Using Slayer > Adjust Steam Tank Pressure on page #28.

#### Option 4: Hot Water Dose

- Hot water dose timer setting, measured and displayed in seconds
- Minimum setting: 0.0 seconds (off)  
Maximum setting: 20.0 seconds  
Adjustable in tenth-second (0.1-second) increments

To adjust the hot water dose, see instructions under Using Slayer > Adjust Hot Water Dose on page #29.

#### Option 5: Automatic Group Cleaning Program

- Fast Clean
- Group Clean

To initiate the group cleaning program, see instructions under Cleaning & Preventative Maintenance > Backflush the Groupheads on page #35.

## ADVANCED MENU

The second level of navigation is the Advanced Menu, which contains the options listed below. While navigating the Barista Menu, access the Advanced Menu at any time by pressing in the jog wheel and holding for five (5) seconds.

**Do not interact with the Advanced Menu before reading this manual in its entirety. Then – if unsure – consult your Slayer representative, reseller, or qualified service personnel.**

#### Advanced Option 1: Heater Control Element On/Off

- Heating element controls for brew tanks, steam tank, and vaporizer

To adjust the heater controls, see instructions under Using Slayer > Other Menu Actions on page #30.

#### Advanced Option 2: Temperature Choose C or F

- Unit of temperature measurement setting: Celsius (C) or Fahrenheit (F)

To adjust the unit of temperature measurement, see instructions under Using Slayer > Other Menu Actions on page #30.

#### Advanced Option 3: Language

- Choose between English, Spanish, German, Italian, or French

To adjust the language, see instructions under Using Slayer > Other Menu Actions > Change Language on page #32.

#### Advanced Option 4: Shot Lights Adj. Brightness

- Brightness setting for shot lights, represented with a percentage value relative to maximum brightness
- Minimum setting: 0% (off)
- Maximum setting: 100%  
Adjustable in .01 increments

To adjust the shot lights setting, see instructions under Using Slayer > Other Menu Actions on page #30.

### **Advanced Option 5: Auto-Flushing**

The Auto-Flushing feature works to stream line busy bar flow and keep the group head flushed and fresh between brews. By enabling the feature in the Advanced Menu you enable a two second flush of brew group water to exit the group directly into the drain tray by simply moving the Actuator back to the OFF position. This feature was designed to improve workflow and encourage cleanliness of the group before each extraction. Factory settings for the Auto Flush are set to the Off position, <Disabled>.

- Enable or Disable

To enable the feature, see instructions under Advanced Menu Actios on page #33.

### **Advanced Option 6: Set Time/Day**

- Time, date, and clock type settings

To adjust the time, date, or clock type, see instructions under Using Slayer > Other Menu Actions on page #31.

### **Advanced Option 7: Times for Power Save to Begin**

You must set the Time/Day to proceed with the setup of powersave mode.

- Power-save settings, with separate schedules for each day individually
- When power-save is "OFF", all systems normal
- When power-save is "ON", machine is in sleep mode
  - Steam pressure reduced to 0.3 bar
  - Brew temperature reduced to 100.0° F
- All systems begin heating for normal operation thirty (30) minutes before power-save is scheduled "OFF"

To configure the power-save program, see instructions under Using Slayer > Other Menu Actions on page #31.

### **Advanced Option 8: Brew Temp Offset**

**To configure the offsets, you must have a scace device or defer to a certified Slayer technician.**

- Brew temperature calibration settings, used to ensure accurate heating by compensating for physical variations between temperature probes
- Use offset to adjust displayed brew temperature, when different from actual
- Adjustable in tenth-degree (0.1-degree) Fahrenheit increments

To adjust the brew temperature offset, see instructions under Using Slayer > Other Menu Actions on page #31.

### **Advanced Option 9: Flow Meter Calibration**

Flow meters are Factory set at 30g (dose A) 60g (dose B). This configuration is defined by three different measurements:

- Volume of water it takes to fill the headspace (water from the puck surface up to the dispersion screen
- the average volume of water left behind in a saturated puck
- the released water through the three way valve at the end of a shot.

If your yield does not match the readings in the barista dashboard, you will need to calibrate your Flow Meter.

To initiate the flow meter calibration, see instructions under Using Slayer > Other Menu Actions on page #32.

## Prepare Espresso

Slayer Steam X utilizes a classic “9-bar” extraction method to produce espresso in a system with custom gicleurs and precision screens. Brew actuators allow for three (3) positions: “off”, “dose 1”, and “dose 2”. A manual mode is also available.

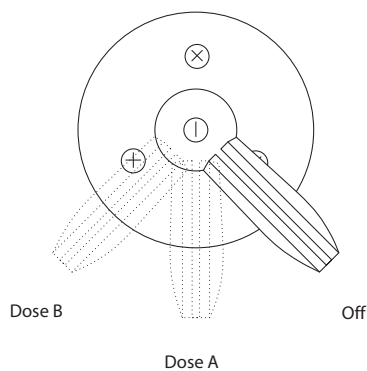

The following steps represent a good starting point when first using Slayer Steam X to prepare espresso.

### INCLUDED PARTS

- Portafilter

### RECOMMENDED SUPPLIES & EQUIPMENT

- Soft, clean towel
- Espresso grinder
- Large portafilter scale

**See complete list on page #9.**

### PROCEDURE

1. Remove the portafilter from the grouphead and wipe the basket with a dry towel.
2. Set the grinder to a degree of coarseness suitable for brewing espresso, a fine powder without clumps.
3. Grind and dose 18-21 grams of coffee into the portafilter.
4. Tamp until the top of the tamper base is level with the rim of the portafilter basket, leaving approximately 1 centimeter of empty space above the puck.
5. Set aside the portafilter while you flush the grouphead, then wipe the grouphead until dry and lock the portafilter into the grouphead.
6. Position a shot glass directly under the portafilter.

**The hole pattern on the drain tray indicates a location that is centered under the portafilter.**

7. Move the brew actuator to one of the “on” positions, “Dose 1” or “Dose 2”.
8. Allow the espresso to brew until the preferred extraction has been achieved (when blanding occurs, when the desired beverage yield has dispensed, or when the desired brew time has elapsed), then move the actuator to the “off” position.
9. Remove the portafilter from the grouphead and discard the puck, then wipe the portafilter with a towel to remove grounds and oil.
10. Flush the grouphead to purge grounds and oil, then return the portafilter to the grouphead.

**Protip: Enable the automatic grouphead flush to clean the brew group after each extraction To enable this feature see page #30.**

## Steam Milk

Slayer Steam X Actuator has three positions. Move the lever up to purge out the steam wand of built up condensation or the post steam purge to push out any steam wand milk residue. OFF is the resting position. Press the lever downward to slide it into the ON position for full steam ahead.

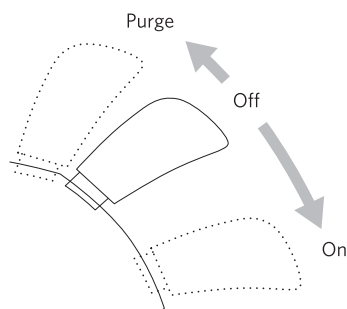

The following steps represent a good starting point when first using Slayer Steam X to prepare milk.

### RECOMMENDED SUPPLIES & EQUIPMENT

- Steaming pitcher
- Soft, clean towel

**See complete list on page #9.**

### PROCEDURE

1. Fill a pitcher with the desired volume of fresh, cold milk.
2. Aim the steam wand toward the drain tray or into a towel and briefly move the steam actuator up to the "purge" position to release steam and condensation.
3. Submerge the steam tip in milk and move the actuator to position A or B.
4. Move the pitcher down to expose the steam tip to the surface of the milk, incorporating fine air bubbles.
5. Submerge the steam tip when the milk reaches body temperature, then tilt the pitcher to form a whirlpool.
6. Turn off the steam wand when the pitcher feels hot to the touch. The final milk temperature should be 55-65° C (130-150° F).

Wipe the steam wand with a damp cloth, removing all milk residue, then purge.

**Protip: Purge the actuator twice within one second to activate a 30 second run cycle, preheating the entire inline system. This feature enables the barista to quickly increase the temperature of all the metal components in resting steam wand, to maintain the consistency of the temperature. Use this feature between long pauses in service (ten minutes or more of down time between drink steaming), start of day, or if you have changed the Vaporizer temperature. To exit the 30 second run cycle early, tap the steam actuator up once.**

## Use Hot Water Tap

Slayer Steam X features a blended hot water valve that draws from the steam tank and main cold water line. The hot water tap is located on the left side of the machine, adjacent to the steam wand. Water volumes may be configured in the Barista Dashboard.

Dispense hot water by pressing the button to right of the tap. The flow of water will stop automatically, after the pre-configured volume has been dispensed. To adjust the volume and temperature, see instructions under Using Slayer > Adjust Hot Water Dose on page #29 and Adjust Hot Water Temperature on page #29.

## Adjust Hot Water Temperature

Custom water temperatures can be raised or lowered to your desired temperature at the mix valve. To adjust the hot water temperature, see instructions under Using Slayer > and Using Slayer > Adjust Hot Water Temperature on page #31.

Frequent or heavy use of the hot water tap may result in reduced steam tank pressure and temperature, causing decreased steaming ability.

## Adjust Drain Tray

Slayer Steam X features an adjustable-height drain tray with four (4) distinct positions.

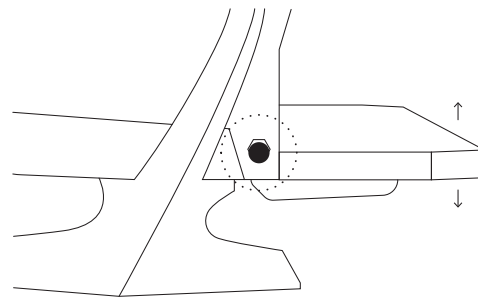

Use the following steps to adjust the height.

1. Locate the two (2) locking pins, one (1) on each side of the drain tray.
2. Clear the drain tray of any items that are subject to tipping, such as shot glasses or tall cups.
3. Brace the drain tray with one hand, then pull one locking pin while sliding the drain tray into the desired position, one side at a time. Release the locking pin to set the tray height.

**Do not use excessive force to move the drain tray.**

4. Repeat step 3 with other side of the drain tray.

**WARNING: When adjusting the drain tray keep a firm grip on the tray ends, as it was designed to be fully removable for easy washing. Failure to hold the tray ends while pulling the side tabs for height adjustment will result in the tray falling to the counter.**

## Adjust Brew Pump Pressure

### INCLUDED PARTS

- External rotary pump
- Inline pump regulator

### REQUIRED TOOLS

- None

### PROCEDURE

1. Locate the pressure gauge and adjustment screw on the external rotary pump.
2. Move the brew actuator to the on position.
3. Turn clockwise to increase the pump pressure. Turn counterclockwise to decrease the pump pressure.
4. Return the brew actuator to the off position.

## Adjust Brew Volumes

Slayer Steam X features automatic-volumetric operation, which is based on readings from the flow meter. The left group screen is the main menu for all machine adjustments. Additionally, each grouphead has two (2) programmable shot volumes: "dose A" and "dose B". Adjust the doses with the following steps:

### PROCEDURE

1. Press and release the jog wheel above the left grouphead to activate the menu for all groupheads.
2. Rotate the jog wheel clockwise until the "Brew Volume" setting appears.
3. Press and release the jog wheel to enter the "Brew Volume" setting. The option to adjust "dose A" will be presented.
4. Rotate the jog wheel to adjust the shot volume for "dose A" in tenth-gram (0.1-gram) increments: clockwise rotations increase the dose; counter-clockwise rotations decrease the dose.
5. Press and release the jog wheel to confirm your new setting and proceed to the next step; the option to apply your new setting to all groupheads will be presented.
6. Rotate the jog wheel to cycle between "N" and "Y". Selecting "N" will apply your new setting to the designated grouphead only; selecting "Y" will apply your new setting to all groupheads.
7. Press and release the jog wheel to confirm your new setting and proceed to the next shot volume; the option to adjust "dose B" will be presented.

To configure different doses for each grouphead, repeat steps 1-7 at each grouphead.

**Note:** When using a scale to measure output, if the weight in the glass does not match the adjusted shot volume, you may need to calibrate your flow meters. To calibrate your flow meter, see instructions on page #23.

## Adjust Brew Tank Temperatures

At the factory, the brew tank temperatures are set to 93° C (200° F). Adjust the brew tank temperatures with the following steps.

### PROCEDURE

1. Press and release the jog wheel above the left grouphead to activate the menu for all groupheads.
2. Rotate the jog wheel clockwise until the "Brew Temperature" setting appears.
3. Press and release the jog wheel to enter the "Brew Temperature" setting.
4. Rotate the jog wheel to adjust the brew tank temperature in tenth-degree (0.1-degree) increments: clockwise rotations increase the temperature; counter-clockwise rotations decrease the temperature.
5. Press and release the jog wheel to confirm your new setting and proceed to the next step; the option to apply your new setting to all groupheads will be presented.
6. Rotate the jog wheel to cycle between "N" and "Y". Selecting "N" will apply your new setting to the designated grouphead only; selecting "Y" will apply your new setting to all groupheads.
7. Press and release the jog wheel to confirm your new setting and return to the menu, and scroll to the next menu option.

To configure a different temperature for each brew tank, repeat steps 1-7 at each grouphead.

**Protip: To quick exit the program menu move the actuator Left/Right to Save and Exit the menu.**

## Adjust Steam Tank Pressure

At the factory, the steam tank temperature is set to 1.7 bar (25 psi). Adjust the steam tank temperature with the following steps.

### PROCEDURE

1. Press and release the jog wheel above any grouphead to activate the menu.
2. Rotate the jog wheel clockwise until the "Steam Tank" setting appears.
3. Press and release the jog wheel to enter the "Steam Tank" setting.
4. Rotate the jog wheel to adjust the steam tank pressure in tenth-bar (0.1-bar) increments: clockwise rotations increase the temperature; counter-clockwise rotations decrease the temperature.
5. Press and release the jog wheel to confirm your new setting and return to the menu, or press and hold the jog wheel to confirm your new setting and exit the menu.

## Adjust Hot Water Dose

Slayer Steam X utilizes a timer to dispense pre-configured volumes of hot water. Adjust the hot water dose with the following steps.

### PROCEDURE

1. Press and release the jog wheel above the left grouphead to activate the main menu.
2. Rotate the jog wheel clockwise until the "Hot Water Dose" setting appears.
3. Press and release the jog wheel to enter the "Hot Water Dose" setting. The "on" button, found directly next to the hot water tap, will begin to flash.
4. Rotate the jog wheel to adjust the hot water dose in tenth-second (0.1-second) increments: clockwise rotations increase the hot water dose; counter-clockwise rotations decrease the hot water dose.
5. Press and release the jog wheel to confirm your new setting and return to the menu, or press and hold the jog wheel to confirm your new setting and exit the menu.

Alternatively, after completing steps 1-3, you may skip to the "Alternative Procedure", below.

### ALTERNATIVE PROCEDURE

1. Complete "Adjust Hot Water Dose" steps 1-3, above.
2. Press and release the "on" button to dispense hot water. The Barista Dashboard will begin a timer to display and record the duration of the dose.
3. Press and release the "on" button again to stop the flow of hot water. The duration of the dose will be recorded.  
**The hot water dose may not exceed 20 seconds.**
4. Press and release the jog wheel to confirm your new setting and return to the menu, or press and hold the jog wheel to confirm your new setting and exit the menu.

## Adjust Hot Water Temperature

Slayer Steam X features a blending valve that draws water from the steam tank and main cold water line simultaneously. Custom water temperatures are configured with the blending valve. Adjust the hot water temperature with the following steps.

### REQUIRED TOOLS

- Flat Blade Screwdriver

### PROCEDURE

1. Remove the cups and tray. You will NOT need to remove the back or side panels to make this adjustment.
2. Locate the blending valve between the Vaporizer and the Proportional valve. [see attached photo]
3. Adjust the hot water temperature from the rear right side of the machine (guest experience side): clockwise rotations increase the hot water temperature; counter-clockwise rotations decrease the hot water temperature.
4. Verify the temperature at the hot water tap with a digital thermometer.

## Other Menu Actions

Through the Advanced Menu, you may access additional settings. Do not interact with the Advanced Menu before reading this manual in its entirety, then – if unsure – consulting your Slayer representative, reseller, or qualified service personnel.

From the idle screen, access the Advanced Menu by pressing and holding the jog wheel, until a beep sounds. At any time, you may press and hold the jog wheel or move the actuator Left to Right to save your new settings and exit the menu.

### HEATER CONTROL ELEMENT ON/OFF

1. Press and hold the jog wheel above the left grouphead for five seconds to activate the Advanced Menu options. Press and release the jog wheel to enter the "Heater Control" setting. The option to adjust all heating elements, universally, will be presented.
2. Rotate the jog wheel to cycle between "On" and "Off".
3. Press and release the jog wheel to confirm your new setting and proceed to the next step.
4. Repeat steps 4-5 for all remaining settings:
  - Gp1 (heating element for leftmost brew tank)
  - Gp2 (on 2-group, right brew tank; on 3-group, middle brew tank)
  - Gp3 (rightmost brew tank; 3-group only)
  - Stm (steam tank)

### TEMPERATURE CHOOSE C OR F

1. Press and hold the jog wheel above the left grouphead for five seconds to activate the Advanced Menu options.
2. Rotate the jog wheel clockwise until the "Temperature" setting appears.
3. Press and release the jog wheel to enter the "Temperature" setting. The option to adjust the unit of temperature measurement will be presented.
4. Rotate the jog wheel to cycle between "C" (Fahrenheit) and "F" (Celsius).

5. Press and release the jog wheel to confirm your new setting and return to the menu for additional adjustments OR move the brew actuator Left to Right to save and exit the Advanced Menu.

### SHOT LIGHTS ADJUST BRIGHTNESS

1. Press and hold the jog wheel above the left grouphead for five seconds to activate the Advanced Menu options.
2. Rotate the jog wheel clockwise until the "Shot Lights" setting appears.
3. Press and release the jog wheel to enter the "Shot Lights" setting. The option to adjust the brightness of all shot lights will be presented.
4. Rotate the jog wheel to adjust the brightness of all shot by a percentage value. (0 is OFF to 100%) increments: clockwise rotations increase the brightness; counter-clockwise rotations decrease the brightness.
5. Press and release the jog wheel to confirm your new setting and return to the menu, OR move the brew actuator Left to Right to save and exit the Advanced Menu

### AUTO FLUSH

1. Press and hold the jog wheel above the left grouphead for five seconds to activate the Advanced Menu options.
2. Rotate the jog wheel clockwise until "Auto-Flushing" setting appears.
3. Press and release the jog wheel to enter the "Auto-Flush" setting. The option is tuned to OFF and will show as <Disabled>, our factory setting.
4. Rotate the jog wheel clockwise one click to the screen <Enable> to activate the setting.
5. Press and release the jog wheel to confirm your new setting and return to the menu for additional adjustments OR move the brew actuator Left to Right to save and exit the Advanced Menu.

#### SET CURRENT TIME/DAY

1. Press and hold the jog wheel above the left grouphead for five seconds to activate the Advanced Menu options.
2. Rotate the jog wheel clockwise until the "Set Time/ Day" setting appears.
3. Press and release the jog wheel to enter the "Set Time/ Day" setting. The option to adjust the clock type will be presented.
4. Rotate the jog wheel to cycle between "12H" (12-hour clock) and "24H" (24-hour clock).
5. Press and release the jog wheel to confirm your new setting and proceed to the next step. The option to adjust the hour will be presented.
6. Rotate the jog wheel to adjust the hour.
7. Press and release the jog wheel to confirm your new setting and proceed to the next step.
8. Repeat steps 6-7 for all remaining settings:
  - Min (minute)
  - Day
9. Press and release the jog wheel to confirm your new setting and return to the menu for additional adjustments OR move the brew actuator Left to Right to save and exit the Advanced Menu.

Time/ Day must be programmed before you can move onto setting up Power Save options.

#### PROGRAM ON/OFF TIMES FOR POWER SAVING

1. Press and hold the jog wheel above the left grouphead for five seconds to activate the Advanced Menu options.
2. Rotate the jog wheel clockwise until the "Times For Power Save To Begin" setting appears.
3. Press and release the jog wheel to enter the "Times for Power Save To Begin" setting. The option to adjust the "on at" setting for the weekday schedule

(Monday-Friday) will be presented.

4. Rotate the jog wheel to adjust the "on at" setting for the weekday schedule to the exact time you want the feature to turn on. The "on at" setting determines the time at which the machine will enter power-save mode and fall asleep.
5. Press and release the jog wheel to confirm your new setting and proceed to the next step; the option to adjust the "off at" setting for the weekday schedule will be presented.
6. Rotate the jog wheel to adjust the "off at" setting for the weekday schedule the exact time you want the feature to turn off. The "off at" setting determines the time at which the machine will be ready to resume normal operations or wake up. The machine will exit power-save mode and begin heating thirty minutes (30 minutes) before the programmed "off at" time.
7. Press and release the jog wheel to confirm your new setting and proceed to the next step. The option to configure the weekend schedule (Saturday-Sunday) will be presented.
8. Repeat steps 4-7 for every day of the week. Adjust accordingly for the weekend schedule to accommodate varied hours of operation.
9. Press and release the jog wheel to confirm your new setting and return to the menu for additional adjustments OR move the brew actuator Left to Right to save and exit the Advanced Menu.

#### BREW TEMP OFFSET

When adjusting a brew temp offset you will need a scale device or the professional services provided by a Slayer technician.

1. Press and hold the jog wheel above the left grouphead for five seconds to activate the Advanced Menu options.
2. Rotate the jog wheel clockwise until the "Brew Temp Offset" setting appears.
3. Press and release the jog wheel to enter the "Brew Temp Offset" setting. The option to adjust the offset for the leftmost grouphead (Gp1) will be presented.
4. Rotate the jog wheel to adjust the brew temperature offset for the leftmost grouphead in tenth-degree (0.1-degree) Fahrenheit increments: clockwise rotations increase the offset value; counter-clockwise rotations decrease the

offset value.

**If the displayed brew temperature is lower than the actual brew temperature, increase the offset value. If the displayed brew temperature is higher than the actual brew temperature, decrease the offset value.**

5. Press and release the jog wheel to confirm your new setting and proceed to the next step.
6. Repeat steps 4-5 for all remaining settings:
  - Gp2 (on 2-group, right brew tank; on 3-group, middle brew tank)
  - Gp3 (rightmost brew tank; 3-group only)
7. Press and release the jog wheel to confirm your new setting and return to the menu for additional adjustments OR move the brew actuator Left to Right to save and exit the Advanced Menu.

#### SET LANGUAGE

1. Press and hold the jog wheel above the left grouphead for five seconds to activate the Advanced Menu options.
2. Rotate the jog wheel clockwise until the "Language" setting appears.
3. Press and release the jog wheel to enter the "Language" setting.
4. Scroll to select your desired Language.
5. Press and release the jog wheel to confirm your language and return to the menu for additional adjustments OR move the brew actuator Left to Right to save and exit the Advanced Menu.

#### CALIBRATE YOUR FLOW METERS

1. Press and hold the jog wheel above the left grouphead for five seconds to activate the Advanced Menu options.
2. Rotate the jog wheel clockwise until the "FlowMeter Calib." setting appears.
3. Press and release the jog wheel to enter the "FlowMeter Calib" setting.
  - Adjust this value up or down based on the need to increase or decrease the

water volume.

- Factory settings will not fit every recipe, therefore fine tuning your volumetrics to match the output on your scale is the best way to achieve consistency
4. Once you have achieved your desired value, press the jog wheel to save. You will immediately be prompted to enter a value for Group 2 and Group 3 (if applicable).
  5. Press and release the jog wheel to confirm and save the settings.

# Cleaning & Preventative Maintenance

Keeping your machine clean and properly maintained is essential to ensuring espresso quality and equipment longevity. Espresso machines require both daily cleaning and ongoing periodic maintenance. The frequency

with which these tasks should be completed will depend on the location and use of your espresso machine. The following instructions assume heavy use in a commercial setting.

## Contents

- 34 Clean Your Machine
- 34 Clean the Steam Wands
- 35 General Grouphead Care
- 35 Backflush the Groupheads
- 36 Backflush the Groupheads, continued
- 37 Fast Clean

## Clean the Machine Exterior

Use a soft, clean towel to wipe the surfaces of the machine. Do not use abrasive cleaners. Small amounts of window cleaner may be used on glass and metal components.

## Clean the Steam X Wands

Immediately after steaming milk, clean the exterior of the steam wand by wiping it thoroughly with a damp towel, then clear the interior by briefly moving the steam actuator up to the "purge" position.

If clogging occurs, soak the steam wand in hot water for several minutes, then purge while submerged. For tough clogs, use an approved espresso machine steam wand cleaning solution.

## General Grouphead Care

Regular cleaning and backflushing optimizes machine performance and espresso flavor by preventing the buildup of coffee oils. Complete the following steps for each grouphead as part of every backflush cycle or as needed, at least once daily.

### REQUIRED TOOLS

- Cleaning brush
- Flat-head screwdriver

### RECOMMENDED SUPPLIES

- Soft, clean towel

### PROCEDURE

1. Remove portafilter from grouphead, then use a cleaning brush to scrub the portafilter gasket, loosening oil and coffee grounds.
2. Use a flat-head screwdriver to remove the dispersion screw and shower screen, then rinse with clean water.

**Ensure that the dispersion screw holes remain clear of coffee grounds, as they may otherwise damage internal parts of the grouphead.**

3. Use a damp towel to wipe oil and grounds from the face and sides of the dispersion block, as well as the portafilter body.
4. Return the clean dispersion screw and shower screen to the grouphead.

**Failure to reinstall the dispersion screw and shower screen before next use may cause the grouphead to clog. Do not attempt to brew espresso or backflush the grouphead before the dispersion screw and shower screen have been correctly installed.**

5. Rinse the portafilter with hot water, then insert the portafilter basket and lock it in the grouphead.

## Backflush the Groupheads

Through the Barista Dashboard, Slayer Steam X automates backflush cycles for each grouphead. Backflush with an approved espresso machine cleaning powder at least once daily. Complete the “Fast Clean” procedure as needed.

To maximize efficiency and lengthen the life of wearable parts, keep on hand two (2) complete sets of shower screens, dispersion screws, portafilter baskets, and portafilter springs. Alternate between sets for each full backflush cycle.

### INCLUDED PARTS

- Blind portafilter insert
- Replacement portafilter

### REQUIRED TOOLS

- Cleaning brush
- Flat-head screwdriver

### RECOMMENDED PARTS & SUPPLIES

- Replacement shower screens, one (1) per grouphead
- Replacement dispersion screws, one (1) per grouphead
- Replacement portafilter baskets, one (1) per grouphead
- Replacement portafilter springs, one (1) per grouphead
- Approved espresso machine cleaning powder
- 1-liter (or larger) heat-tolerant container
- Soft, clean towel

## Backflush the Groupheads, continued

### PROCEDURE

1. Complete "General Group Cleaning" steps 1-3 on page #35. Set aside shower screens and dispersion screws.
2. Prepare a solution of hot water and approved espresso machine cleaning powder in a 1-liter (or larger) heat-tolerant container.
3. Remove portafilter baskets and portafilter springs from all portafilter bodies.
4. Add all shower screens, dispersion screws, portafilter baskets, portafilter springs, and portafilter bodies to prepared solution. Soak for a minimum of 20 minutes, then rinse thoroughly with clean water. Meanwhile, complete remaining steps.

**Do not submerge portafilter handles in solution or fading will occur.**

5. Use a flat-head screwdriver to install a second set of shower screens and dispersion screws, then complete the following steps for each grouphead.
6. Install a blind insert in a replacement portafilter, add cleaning powder, and lock it in the grouphead.
7. Press and release the jog wheel above the grouphead to activate the menu.
8. Rotate the jog wheel clockwise until the "Group Cleaning" setting appears.
9. Press and release the jog wheel to enter the "Group Cleaning" setting. The option to select a cleaning program will be presented.
10. Rotate the jog wheel to cycle between cleaning programs:
  - All (all groupheads)
  - Gp1 (leftmost grouphead)
  - Gp2 (on 2-group, right grouphead; on 3-group, middle grouphead)
  - Gp3 (rightmost grouphead; 3-group only)
11. Press and release the jog wheel to select and initiate a cleaning program. A countdown will begin at the grouphead(s) running the cleaning program. The cleaning program is complete when a buzz sounds and the shot light pulses.
12. Follow the prompt on the screen to remove the portafilter(s) from the

grouphead(s), then press and release the jog wheel to continue. A purging cycle will begin at the grouphead(s) running the cleaning program. The purging cycle is complete when the shot light pulses, after approximately thirty (30) seconds.

13. Reassemble the portafilter, inserting the portafilter spring and portafilter basket, then lock it in the grouphead.
14. Repeat steps 6-13 for each grouphead, as needed.

## Fast Clean

Designed to be done without the use of detergent after the busy portion of the day, at the shift change or when changing out the coffees in the hopper. Leave the screen, screw in place. Complete the following steps for each grouphead whenever your machine requires minor cleaning.

### INCLUDED PARTS

- Blind portafilter insert

### REQUIRED TOOLS

- group brush or non-fiber towel and a blunt end object

### RECOMMENDED SUPPLIES

- Soft, clean towel

### PROCEDURE

1. Remove portafilter from grouphead, then use a cleaning brush to scrub the portafilter gasket, loosening oil and coffee grounds.
2. Replace portafilter basket with a blind insert and lock it in the grouphead.
3. Press and release the jog wheel above the grouphead to activate the menu.
4. Rotate the jog wheel counterclockwise to the "Fast Clean" setting
5. Press and release the jog wheel to enter the "Fast Clean" setting. The option to select a cleaning program will be presented.
6. Press and release the jog wheel to select and initiate Fast Clean.
7. Follow the prompt on the screen to remove the portafilter from the grouphead, then press and release the jog wheel to continue.

8. Remove the blind insert from the portafilter and use a damp towel to wipe oil and grounds from portafilter body.
9. Rinse the portafilter with hot water, then insert the portafilter basket and lock it in the grouphead.
10. Repeat all steps for each grouphead, as needed. This feature is available per group and intuitively placed last on the menu for counter clockwise turn to, quick activation.

# Part Diagrams

Preventative maintenance and appropriate water filtration will not only extend the life of your espresso machine, it will additionally maintain the output of high quality beverages. Only qualified service personnel should repair

Slayer Espresso machines. Incorrect repair may result in injury and/or damage to the equipment. Please consult your distributor for a qualified Slayer service technician.

## Contents

39	Brew Tank Assembly
40	Group Cap Assembly
41	Steam Tank Assembly
42	Steam Manifold Assembly
43	Water Inlet Manifold Assembly
44	Hot Water Mix Valve
45	Drain Manifold Assembly
46	Flow Meter Assembly
47	Steam Actuator Assembly
48	Barista Dashboard Upper Panel Display
49	Barista Dashboard Display Assembly
50	Electronics Panel
51	Wing Assembly

## Brew Tank Assembly

ITEM NO.	PART NUMBER	DESCRIPTION	QTY.
1	10000-16051	BREW CAP	1
2	42000-34300	BLEED SCREW PLUG	2
3	44000-56000	BAYONET BOLT	3
4	44000-36130	SCREW/WASHER POWER SUPPLY	2
5	30000-20040	MAGNETIC SWITCH N/O	2
6	44000-56000	BAYONET BOLT	3
7	42000-34560	1/4 COMP 90 DEG	2
8	15005-16060	TANK	1
9	46000-50070	58 MM SHOWER SCREEN	1
10	46000-50080	DIFFUSER SCREW	1
11	46000-56090	PORTAFILTER GASKET	1
12	20000-56010	BAYONET RING	1
13	46000-50100	GROUP CAP PAPER GASKET	1
14	30000-20140	ELEMENT GASKET	1
15	30000-20130	600 WATT BREW TANK ELEMENT	1
16	44000-36070	3/8 LOCK WASHER	4
17	44000-36080	3/8-16 NUT	4
18	30000-20250	100 DEG C THERMOSTAT	1
19	30000-20151	3 WAY SOLENOID VALVE	1
20	44000-36310	MOUNT SCREW	2
21	46000-50090	GROUP CAP O RING	1
22	10000-16061	.7MM GIGGLEUR	1
23	44000-36000	INVERTED MAG SWITCH SPACER	2
24	44000-36140	SCREW/WASHER FOR INVERTED MAGNET	2
25	30005-20080	3K3 NTC	1

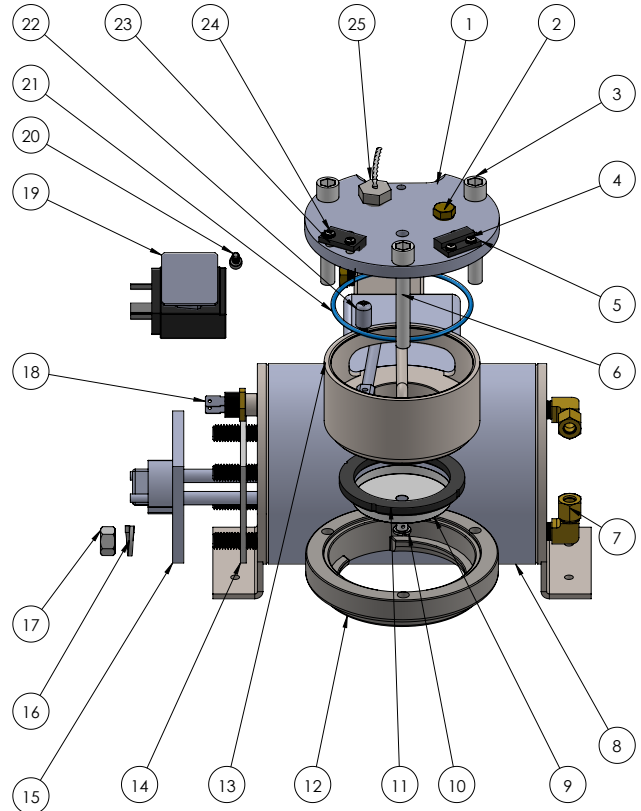

<b>SLAYER</b> WWW.SLAYERESPRESSO.COM 206-284-7171	NAME
	99005-16060

## Group Cap Assembly

ITEM NO.	PART NUMBER	DESCRIPTION	QTY.
1	99005-56500		1
2	20000-16080	GROUP COVER	1
3	46000-50270	GROUP COVER SPACER	3
4	46000-50240	DISC SPRING	1
5	44000-50220	HANDLE LOCK SCREW	1
6	44000-50210	INSERT NUT	1
7	46000-50190	HANDLE SPACER	1
8	46000-53070	TEFLON GASKET 27MM	1
9	10000-16200	OILITE BUSHING	1
10	44000-50260	GROUP COVER MOUNT SCREW	3
11	10000-16210	PLASTIC SPACER	1
12	44000-16220	STAINLESS FINDER WASHER	1
13	99000-50050	TONGUE ASSEMBLY	1
14	10000-16161	VALVE STEM	1

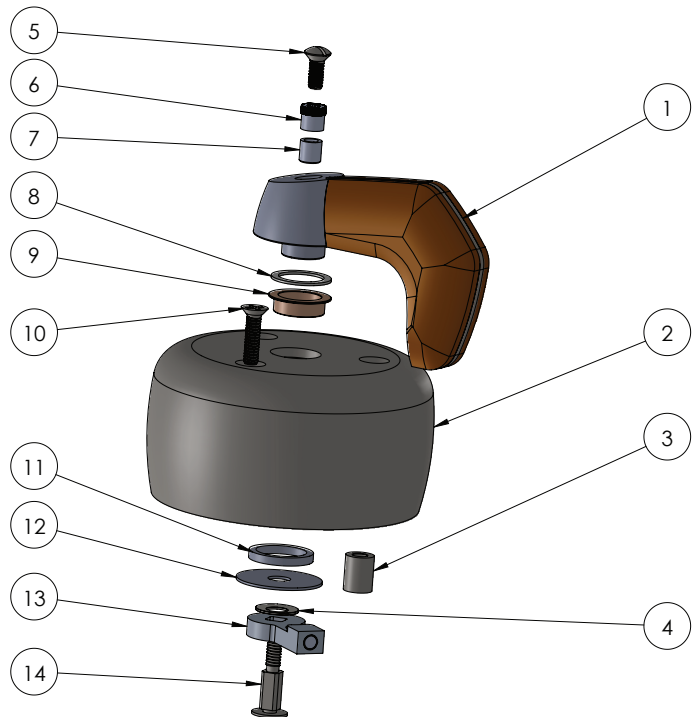

<b>SLAYER</b> WWW.SLAYERESPRESSO.COM 206-284-7171	NAME
	99005-16080

## Steam Tank Assembly

ITEM NO.	PART NUMBER	DESCRIPTION	QTY.
1	15005-13110	TANK BODY, 3 GROUP, STEAM	1
2	42000-34560	1/4 COMP 90 DEG	3
3	42000-34680	STEAM LINE ELBOW	2
4	30000-20260	145 DEG C THERMOSTAT	1
5	30000-20140	ELEMENT GASKET	1
6	30000-20100	STEAM ELEMENT, 220V, 4500W, 3 GROUP	1
7	44000-36080	3/8-16 NUT	4
8	30000-50170	WATER LEVEL PROBE	1
9	46000-50150	COPPER GASKET 1/4 NPT	1
10	44000-36070	3/8 LOCK WASHER	4
11	42000-34702	WATER OUT FITTING	1
12	42000-34500	1/8 NPT X 1/4 COPPER COMP.	1
13	42000-34580	1/8 NPT PIPE TEE M-F-F	1
14	30000-20191	2 WAY SOLENOID	1
15	10999-20191	SOLENOID MOUNT	1
16	46000-50290	1/8 BALL VALVE	1
17	42000-34110	1/8 NPT 90 DEG ELBOW M-F	1
18	42000-34180	1/8 NPT HEX NIPPLE	2

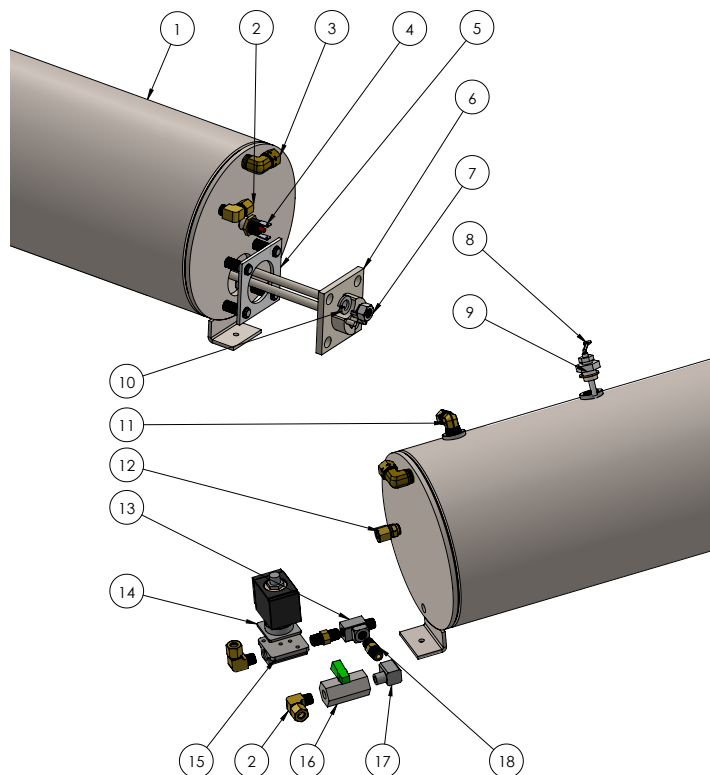

<b>SLAYER</b> WWW.SLAYERESPRESSO.COM 206-284-7171	NAME
	99005-13110

## Steam Manifold Assembly

ITEM NO.	PART NUMBER	DESCRIPTION	QTY.
1	46000-50120	PRV 2.5 BAR	1
2	46000-50140	VACUUM BREAKER	1
3	46000-50130	COPPER GASKET 3/8 NPT	1
4	46000-50150	COPPER GASKET 1/4 NPT	1
5	10005-03030	WATER INLET MANIFOLD	1
6	42000-34500	1/8 NPT X 1/4 COPPER COMP.	1

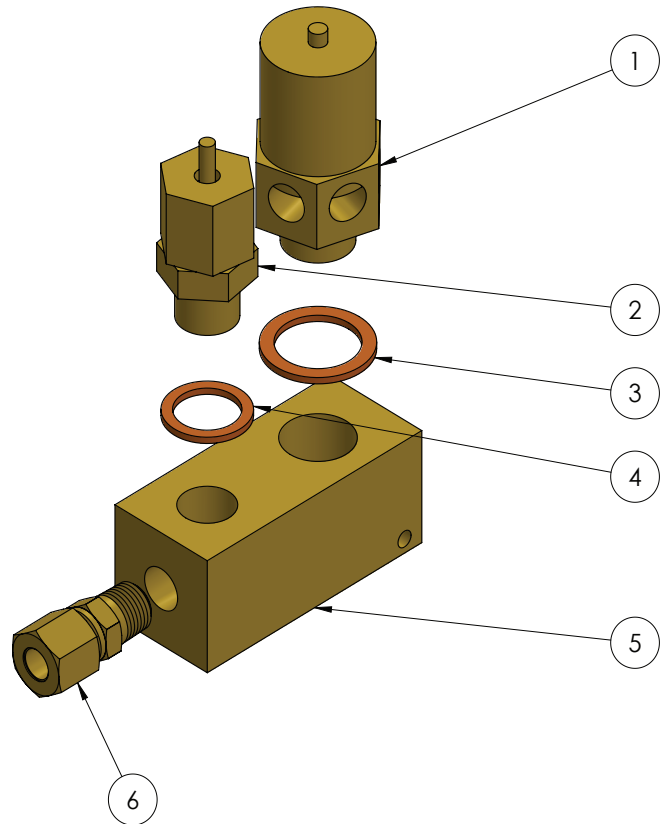

<b>SLAYER</b> WWW.SLAYERESPRESSO.COM 206-284-7171	NAME
	99005-03030

## Water Inlet Manifold Assembly

ITEM NO.	PART NUMBER	DESCRIPTION	QTY.
1	46000-50110	EXPANSION VALVE	1
2	46000-50150	COPPER GASKET 1/4 NPT	1
3	42004-34510	TRANSDUCER ELBOW	1
4	42000-34500	1/8 NPT X 1/4 COPPER COMP.	4
5	10005-03050	WATER INLET MANIFOLD	1
6	42000-34300	BLEED SCREW PLUG	1
7	46005-34620	1 WAY VALVE	1
8	42000-10010	3/8 WATER INLET FITTING	1
9	42004-34500	PRV ELBOW	1

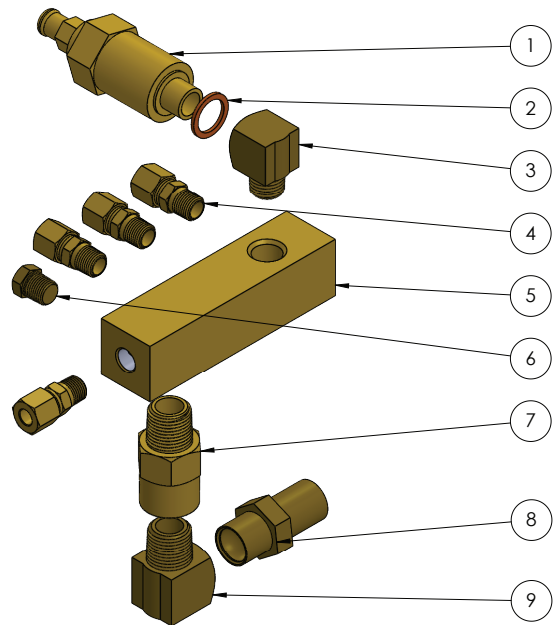

<b>SLAYER</b> WWW.SLAYERESPRESSO.COM 206-284-7171	NAME
	99005-03050

## Hot Water Mix Valve

ITEM NO.	PART NUMBER	DESCRIPTION	QTY.
1	40005-32070	COLD WATER IN TUBE	1
2	42000-34560	1/4 COMP 90 DEG	1
3	30003-20351	HOT WATER MIX SOLENOID	1
4	42000-34500	1/8 NPT X 1/4 COPPER COMP.	1
5	40005-32060	Hot Water to Mix Valve Tube	1

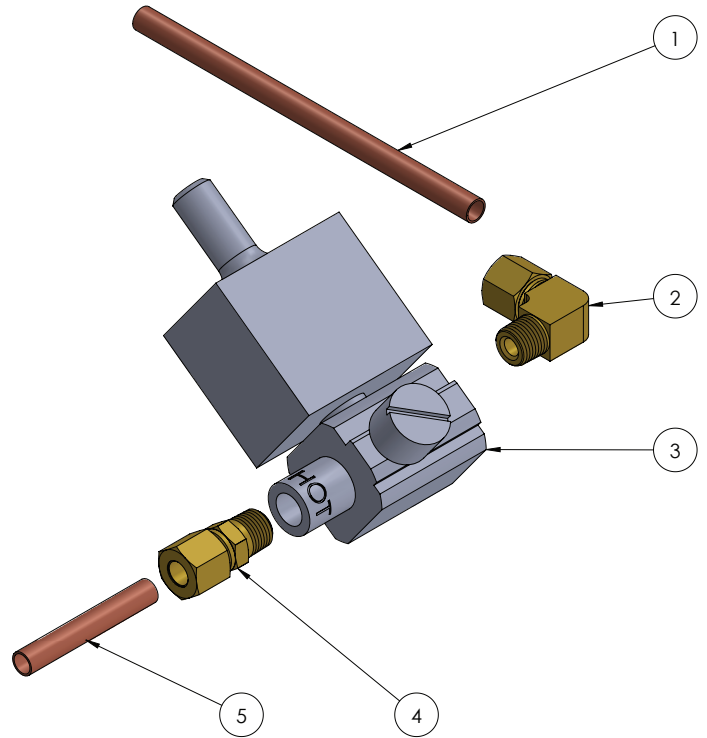

<b>SLAYER</b> WWW.SLAYERESPRESSO.COM 206-284-7171	NAME
	99005-20351

## Drain Manifold Assembly

ITEM NO.	PART NUMBER	DESCRIPTION	QTY.
1	42000-34560	1/4 COMP 90 DEG	1
2	13005-30018 13005-20018	DRAIN MANIFOLD, 3GRP DRAIN MANIFOLD, 2GRP	1
3	42000-34180	1/8 NPT HEX NIPPLE	4
4	42000-34500	1/8 NPT X 1/4 COPPER COMP.	3
5	42005-10000	5/16 HOSE BARB	2
6	42000-34220	PUSH CONNECT FITTING	1

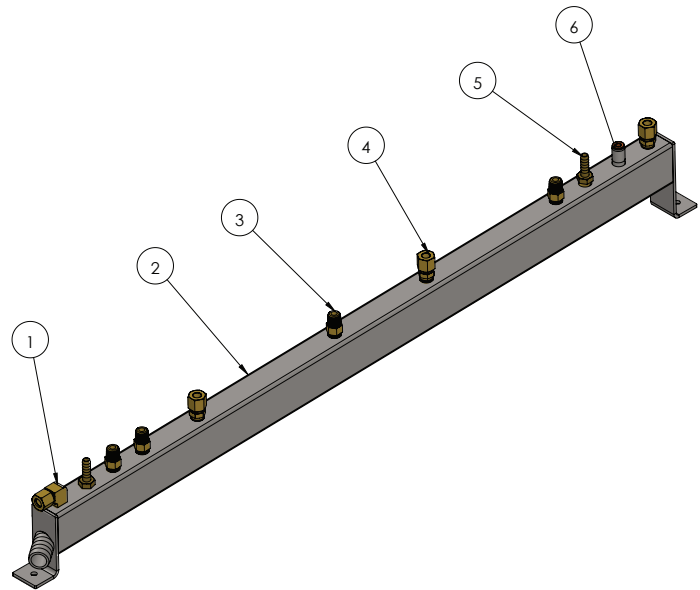

<b>SLAYER</b> WWW.SLAYERESPRESSO.COM 206-284-7171	NAME
	99005-30018

## Flow Meter Assembly

ITEM NO.	PART NUMBER	DESCRIPTION	QTY.
1	40005-32110	TO BREW TANK TUBE	1
2	42000-34700	WATER INLET FITTING	1
3	42000-34702	WATER OUT FITTING	1
4	30005-30170	FLOW METER	1

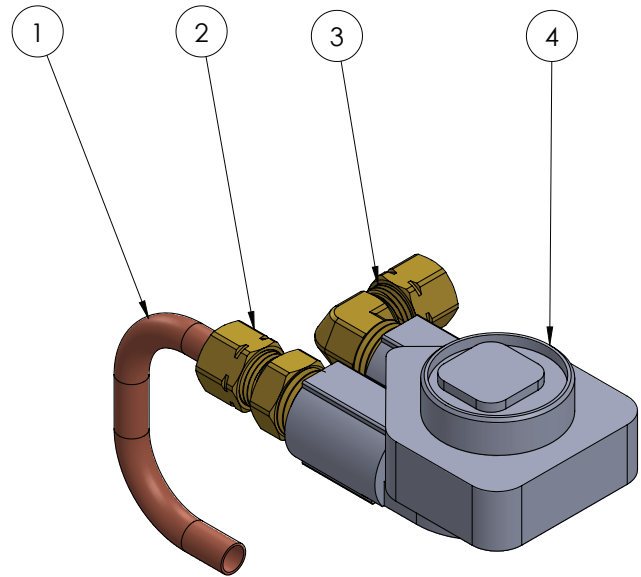

<b>SLAYER</b> WWW.SLAYERESPRESSO.COM 206-284-7171	NAME
	99005-30170

## Steam Actuator Assembly

ITEM NO.	PART NUMBER	DESCRIPTION	QTY.
1	99005-30036	STEAM ACTUATOR HANDLE	1
2	10005-10003 10005-10004	RIGHT ACTUATOR BODY LEFT ACTUATOR BODY	1
3	44000-36310	MOUNT SCREW	2
4	46003-50062	3/16 MAGNET	1
5	46000-10000	PLASTIC BUSHING	1
6	46003-50060	1/4 MAGNET	2

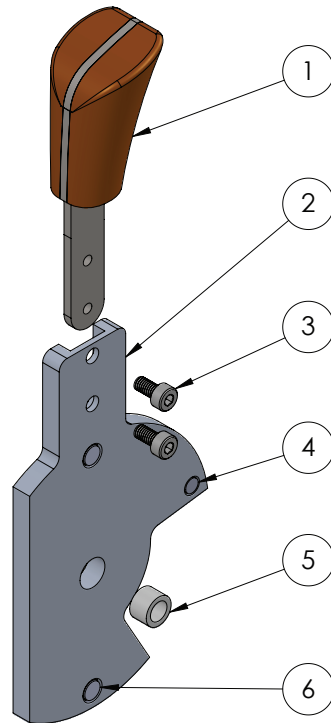

<b>SLAYER</b> WWW.SLAYERESPRESSO.COM 206-284-7171	NAME
	99005-10003

## Barista Dashboard Upper Panel Display

ITEM NO.	PART NUMBER	DESCRIPTION	QTY.
1	13005-30026 13005-20026	UPPER FRONT PANEL, 3GP UPPER FRONT PANEL, 2GP	1
2	99005-30020	DISPLAY ASSEMBLY	1
3	10005-03080	Button Ring, Lower	1
4	10005-03070	Button Ring, Upper	1
5	30005-20340	MOMENTARY PUSH BUTTON	1

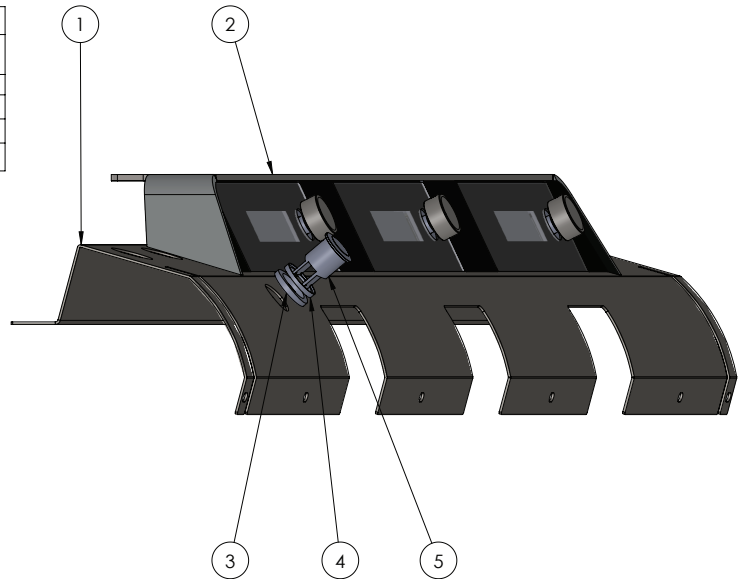

<b>SLAYER</b> <a href="http://WWW.SLAYERESPRESSO.COM">WWW.SLAYERESPRESSO.COM</a> 206-284-7171	NAME
	99005-30026

## Barista Dashboard Display Assembly

ITEM NO.	PART NUMBER	DESCRIPTION	QTY.
1	20005-10003	DISPLAY END LEFT	1
2	44005-10020	RAIL CLIP SCREW	6
3	13005-30052 13005-20052	DISPLAY COVER, 3GP	1
4	20005-10002	DISPLAY ATTACHMENT	2
5	13005-30053 13005-20053	DISPLAY COVER LOWER PANEL 3GRP DISPLAY COVER LOWER PANEL 2GRP	1
6	44005-10130	PANEL MOUNT SCREW	6
7	20005-10000	DISPLAY END RIGHT	1
8	93655A459	THREADED SPACER	2
9	26005-10000	DISPLAY GLASS	3
10	10005-03010	ENCODER KNOB	3
11	92605A102	SET SCREW	3
12	20005-10001	FACE PLATE	3
13	30005-60110	DISPLAY	1
14	30005-20100	OPTICAL ENCODER	3

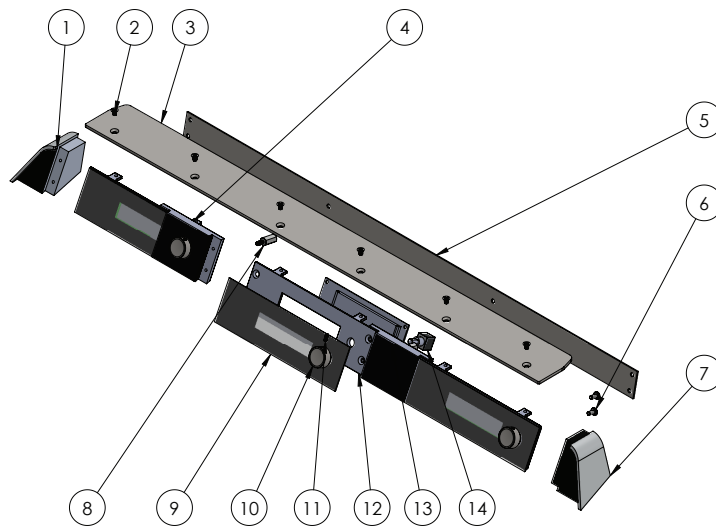

<b>SLAYER</b> WWW.SLAYERESPRESSO.COM 206-284-7171	NAME
	99005-30020

## Electronics Panel

ITEM NO.	PART NUMBER	DESCRIPTION	QTY.
1	13005-30027 13005-20027	ELECTRICAL SHIELD, 3GP ELECTRICAL SHIELD, 2GP	1
2	30000-20011	MINI 20 AMP SSR	5
3	30000-20050	50 AMP RELAY	1
4	30000-20003	POWER SUPPLY	1
5	10005-10005	SUB PLATE	1
6	30005-60100	MAIN BOARD	1
7	44005-10130	PANEL MOUNT SCREW	4
8	44005-10210	RELAY MOUNT BOLT	12

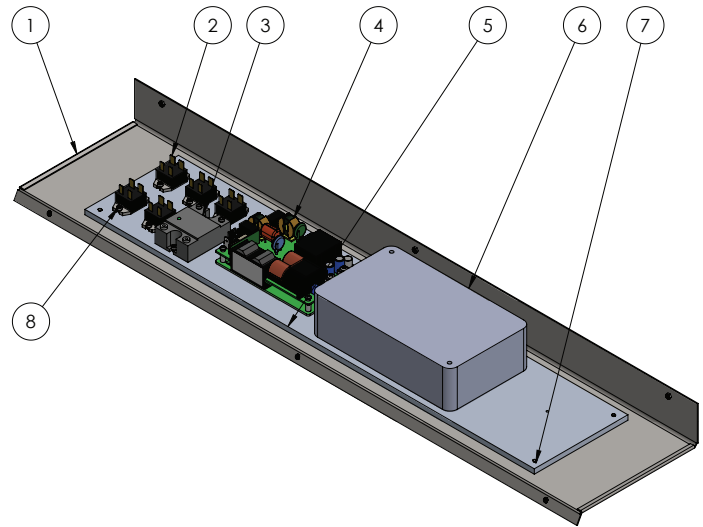

<b>SLAYER</b> WWW.SLAYERESPRESSO.COM 206-284-7171	NAME
	99005-10005

## Wing Assembly

ITEM NO.	PART NUMBER	DESCRIPTION	QTY.
1	44005-10020	RAIL CLIP SCREW	2
2	13005-30047	RAIL CLIP, RIGHT	1
3	20200-10000	WING, RIGHT SIDE	1
4	44005-10110	WING MOUNT BOLT	2
5	46005-50180	RUBBER FOOT	2

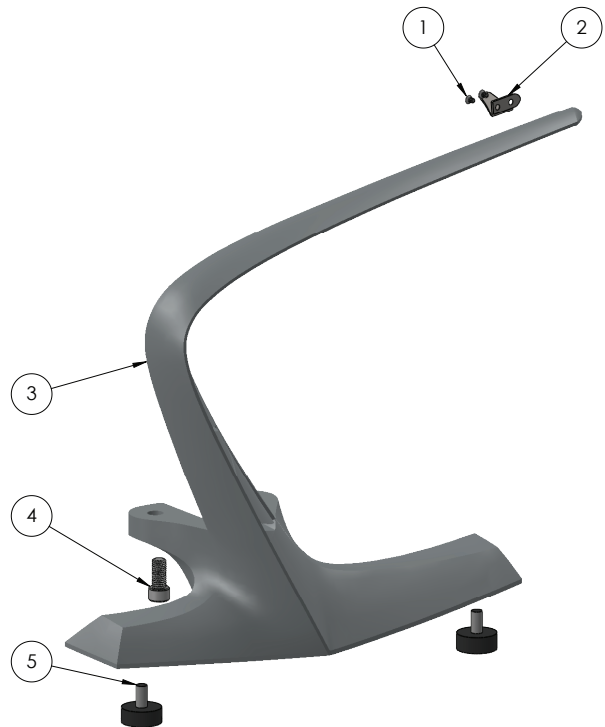

<b>SLAYER</b> WWW.SLAYERESPRESSO.COM 206-284-7171	NAME
	99005-10000