

LADENMÜHLEN | SHOP GRINDER

Operating Instructions Tanzania

”Innovation & Design“



The professional art of grinding
since 1924

Dear Customer,

with the new „Tanzania“ you have purchased a grinder in the well-known MAHLKÖNIG quality.

Over 80 years of experience in the production and development of grinders have helped us to develop a new product in the MAHLKÖNIG company.

As usual, this new product guarantees top-quality by grinding of all types of coffee.

Before putting the grinder into service, please read these operating instructions including the safety instructions carefully and observe them at all times. Also instruct your personnel accordingly.

Enclosed you will find many useful tips that will make it easier for you to use the grinder. Keep these operating instructions in a safe, easily accessible location. In case of any unclear points or additionally required information, please contact your local dealer or us directly as the manufacturer.

MAHLKÖNIG GmbH & Co. KG

Contents

1. Introduction

- 1.1 Safety instructions
- 1.2 Scope of the documentation
- 1.3 Definition of the terms used
- 1.4 Copyright

2 Safety and Warranty

- 2.1 Explanation of safety instructions
- 2.2 General safety instructions
- 2.3 Electrical power
- 2.4 Use in accordance with the intended purpose
- 2.5 Service staff requirements
- 2.6 Warranty and liability

3 Description of the machine

- 3.1 Function principle
 - 3.1.1 Design of the machine
- 3.2 Technical data
 - 3.2.1 Power supply
 - 3.2.2 Noise emission

4 Packaging and transport

- 4.1 Packing the machine
- 4.2 Unpacking the machine

5 Positioning the machine

- 5.1 Installation site requirements

6 Installing the machine

- 6.1 Installation
- 6.2 Installing the collecting tray
- 6.3 Electrical installation

7 Start up

8 Operation

- 8.1 Conditions for machine operation
- 8.2 Operating
- 8.3 Calibrating the machine

9 Maintenance

- 9.1 Cleaning
 - 9.1.1 Removing / Replacing the hopper
 - 9.1.2 Cleaning the grinding mechanism
 - 9.1.3 Cleaning the spout
 - 9.1.4 Cleaning the collecting tray
- 9.2 Replacing components
 - 9.2.1 Replacing the grinding discs
 - 9.2.1.1 Removing the grinding disc in the rotating flange, without screws

9.2.1.2 Removing the grinding disc in the stationary flange, without screws

9.3 Maintenance work on the mains power supply

10 Protection devices / Faults

10.1 Protection devices

10.2 Faults

10.2.1 Fault correction

11 Waste disposal

12 Electrical wiring diagrams

13 Warranty

14 Contact addresses

1. Introduction

1.1 Safety instructions

The Operating Instructions must be kept permanently at the location where the machine is operated and, if possible, fixed in place.

- It is essential that the responsible sales and service staff read the Operating Instructions before starting the machine and that they are familiar with all its functions including procedure in case of malfunction.
- The machine should not be used by persons (including children) with physical, sensory or learning difficulties or who lack sufficient experience and/or know-how, unless they are fully supervised by a person responsible for their health and safety or have received appropriate training about safe machine operation from the said person.
- Children should always be fully supervised to ensure they do not play with the machine.
- Install the machine out of the reach of children.
- If customers are to use the machine themselves, there must be a clearly visible notice in the immediate vicinity of the machine instructing customers to call the responsible sales staff in the event of a fault and warning them not to attempt to correct the fault themselves by tampering with the machine.
- The machine must be located in the sales areas such that customers always have direct access to sales staff.

- Use only original spare parts when repairing the machine. Using spare parts from other manufacturers may impair the serviceability of the machine. In addition, there remains the possibility of further personal injury or material damage.
- Use only original grinding discs sharpened by MAHLKÖNIG.
- Never insert fingers or objects into the bean hopper.
- Never touch the electrical components with conducting objects, such as needles, pins, cutlery etc.!
- Ensure that the machine is electrically protected with circuit breakers or fuses in accordance with the nameplate and local regulations.

1.2 Scope of the documentation

This manual includes the following information:

- Installation of the machine with all available options
- Settings
- Start up
- Use
- Maintenance
- Electrical wiring diagrams

The Operating Instructions are an essential element of the machine and form part of the supply. Always ensure that the Operating Instructions are passed on to the new owner together with the machine, if it is sold.

1.3 Definition of the terms used

In these Operating Instructions, the following terms are used to define all persons who are involved with the Coffee Grinder:

User

The machine operator's customer is defined as the user. The user uses the machine without assistance. There must be a notice instructing the user to consult service staff immediately in the event of a fault. The user must not attempt to correct faults himself by tampering with the machine.

Service staff

Service staff are defined as persons engaged by the operator for the servicing and upkeep of the machine. It is essential that service staff have read and understood the Operating and Maintenance Instructions. Service staff must be familiar with all the functions including procedure in the event of a fault.

Maintenance staff

Maintenance staff are defined as persons engaged by the operator for the installation and maintenance of the machine. The person responsible must have both technical knowledge and practical skills. It is essential that maintenance staff have read and understood the Operating and Maintenance Instructions.

Operator

The operator is defined as the contractual partner of the manufacturer or his representative. The operator has the signature authority to make legally binding agreements. The operator purchases the machine and allows it to be used for the purpose he intends.

1.4 Copyright

These Operating Instructions must be treated in confidence. All the information and data supplied in these Operating Instructions are protected by copyright. Breaches of copyright are an offence and give rise to claims for compensation.

This documentation contains material which is protected by copyright. It may be neither duplicated, copied, microfilmed, nor passed to third parties without the consent of MAHLKÖNIG GmbH & Co. KG.

2 Safety and Warranty

2.1 Explanation of safety instructions

All safety instructions in these Operating Instructions provide timely advice regarding possible dangers of life or injury, possible damage to the machine and how to maintain operation without defects.

All parts that are particularly important feature a warning sign. This information must be read and followed.



WARNING

indicates a hazardous situation which, if not avoided, could result in death or serious injury.



CAUTION

indicates a hazardous situation which, if not avoided, may result in minor or moderate injury.

NOTICE

NOTICE indicates a property damage message.

HINT

HINT provides important information which helps you to utilize the grinder correctly and safely.

2.2 General safety instructions

Take particular note of the following instructions:

- Each person who is concerned with the installation, start up, operation and maintenance (inspection, maintenance, repair) of the machine must have read and understood the whole of the Operating Instructions, and in particular the chapter 2 "Safety and warranty".
- This machine has been manufactured and assembled in accordance with the latest technology. Particular attention has been given to the safety of the user and the ergonomic layout of the operational controls.
- All safety and protection devices are components of a safety design philosophy that has the objective of protecting all persons who work with the machine from any danger.

HINT

No modifications that alter or prevent the functionality or the mode of operation of the safety and protection devices are permitted.

- The machine may only be operated if all safety and protection devices are fitted and are functioning without defects.

HINT

In all activities related to installation, maintenance and repair the switching off procedures pre-scribed in the Operating Instructions must be followed.

- No working procedure that impairs the safety of the machine can be permitted to continue. Service staff are obliged to report immediately any modifications to the equipment that impair safety.
- The operator is obliged to operate the machine only when it is without defects.



Installation, maintenance and repair activities are only to be performed when the equipment is at rest. Before beginning these tasks switch off the machine and pull out the mains plug from the mains socket.

- Before switching on after restoration of operation, check that all protection devices are fitted and fully functional.
- Local safety and accident prevention procedures always apply when the machine is being operated.
- These Operating Instructions are part of the machine. In the event of damage or loss they must be replaced immediately. For this purpose please contact our Customer Services department or an authorized customer service outlet.

2.3 Electrical power



Never touch parts that are exposed to electrical voltage. These can cause an electric shock that can lead to severe injury or death!

Never operate the machine with a defective mains cable. Defective mains cables or plugs must be replaced immediately by authorized specialist personnel or by our Customer Services department.

NOTICE

Before connecting the machine to the mains, check whether the local operating voltage, frequency and circuit breakers/fuses match the data shown on the nameplate and with the technical data in these Operating Instructions. If the data does not match, do not connect the machine to the mains!

2.4 Use in accordance with the intended purpose

The sole function of the Coffee Grinder is to grind whole roasted coffee beans. Any other use is deemed to be not in accordance with the intended purpose.

NOTICE

Only whole coffee beans may be loaded into the bean hopper. Do not put ground coffee into the bean hopper. Coffee that has already been ground once must not be loaded into the bean hopper and reground.

NOTICE

Only coffee beans may be loaded into the bean hopper. Do not put other objects or liquids into the bean hopper, since this will damage the grinder.

HINT

The machine can be dangerous if it is used improperly or not in accordance with the intended purpose. Use in accordance with the intended purpose also includes observation of operating and maintenance conditions as prescribed by the manufacturer.

2.5 Service staff requirements

The machine may only be serviced and maintained by personnel who have been trained and assigned to the equipment. The operator must warn service staff of any hazards that may be present.

The operator must clearly assign responsibilities as to servicing and maintenance, so that, as far as safety is concerned, no one is unclear as to who is responsible for what. The operator must take care that no unauthorized persons perform such tasks on the equipment.

2.6 Warranty and liability

The warranty is limited to the replacement of defective parts. The manufacturer shall not be liable in respect of claims in excess of this. Spare parts must conform to the technical specifications of the manufacturer. Use only MAHLKÖNIG – original spare parts.

The machine must be operated in the prescribed manner as described in these Operating Instructions. No other use of the equipment is permitted. The operator must not convert or modify the machine.

3 Description of the machine

3.1 Function principle

The Coffee Grinder is intended for grinding various types of coffee. An adjusting knob with scale is used to continuously set the fineness of the grind from "Turkish fine" to "Coarse".

The Coffee Grinder is suitable for use in food stores, cafés, restaurants and hotels. Its simple operation enables customers in self-service areas to operate the grinder on their own. The actual operation of the machine may vary slightly from the information specified in these Operating Instructions.

3.1.1 Design of the machine

Names of the components

- | | |
|-------------------|---|
| 1 Cover | 8 Grinding fineness adjusting knob |
| 2 Hopper | 9 ON/OFF-switch |
| 3 Clamping lever | 10 Mains cable |
| 4 Spout | 11 Klixon overload protection
(underneath) |
| 5 Bag shaker | |
| 6 Collecting tray | |
| 7 Grinder cover | |

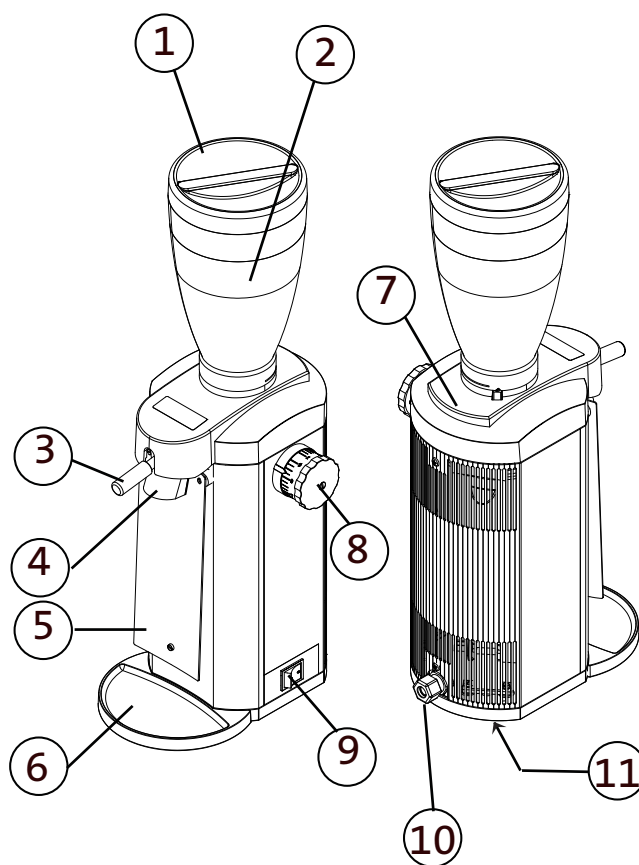

3.2 Technical data

Description	Tanzania
Voltage/Frequency	220-230V / 50/60Hz 115V / 60Hz 100V / 50/60Hz
Grinding disc Ø	80 mm
Rotation	1480 rpm @50Hz 1780 rpm @60Hz
Sound emission idle operation	77 dB(A)
Dimensions (WxHxD)	21x63x30 cm
Weight	16 kg
Hopper capacity	0,7 kg

(Please ask the manufacturer or dealer for technical data on other voltages and frequencies.)

3.2.1 Power supply

The power supply ratings depend on the customer's mains power supply. Please note the nominal ratings on the nameplate fixed to the rear of the machine.

Please see chapter 12 "Electrical wiring diagrams" for the electrical wiring diagrams.

3.2.2 Noise emission

Equivalent persistent noise pressure level when grinding is 77 dB (A).

4 Packaging and transport

4.1 Packing the machine

The machine must be packed appropriately to keep it safe during transport. The machine manufacturer recommends the type of packaging material used for dispatch from the factory.

4.2 Unpacking the machine

Procedure:

1. Bring the machine while still packed as close as possible to the installation site. Read the chapter 5.1 entitled "Installation site requirements".
2. Remove the packaging and check the whole shipment for completeness as detailed on the delivery note and for any damage caused during transport.

- If you discover transport damage, notify both the transport and dispatching companies immediately. Please refer to the chapter 14 entitled "Contact addresses" for the address and contact numbers of the machine manufacturer.

Make a photographic record of the damage. In addition, retain all the packaging material to assist any further clarifications!

- Place the machine in its final position.

The dimensions of the packaging material match those of the machine. We recommend that you store this material in a dry place for any future transport.

5 Positioning the machine

5.1 Installation site requirements

The installation site must be dry and well ventilated. Always install the grinder on a flat, nonskid surface to ensure that it can neither fall over nor slide.

HINT

Keep the machine out of the reach of children. Children do not recognize the dangers associated with electrical equipment.

The mains plug has to be easily accessible after installation!

6 Installing the machine

Remove any adhesive tapes and remaining packaging.

6.1 Installation

Procedure:

- Decide where the machine's final position will be.
- Fit the support surface for the Coffee Grinder. Make sure that the support surface for the machine is flat and stable. Ideal support height for the machine: 750 mm (30") from the floor.

6.2 Installing the collecting tray

Place the collecting tray (1) onto the two mounting brackets (2).

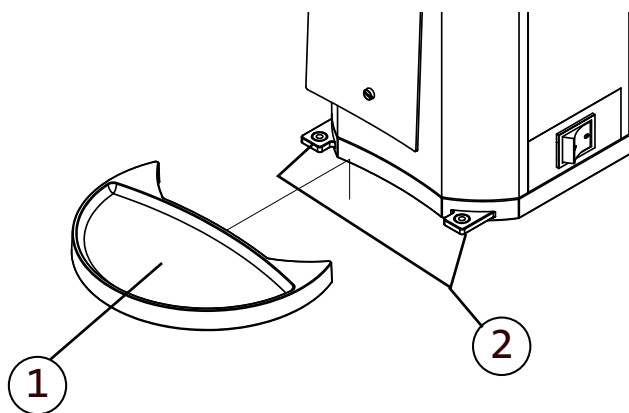

6.3 Electrical installation

NOTICE

Before connecting the machine to the mains, check whether the local operating voltage, frequency and circuit breakers/fuses match the data shown on the nameplate and with the technical data in these Operating Instructions. If the data does not match, do not connect the machine to the mains!

The nameplate is located on the rear of the Coffee Grinder.

- Also, please note the information in the chapter 3.2 entitled “Technical data” and the circuit diagram. The latter is located in the chapter 12 entitled “Electrical Wiring Diagrams”.

7 Start up

HINT

Start up must only be carried out by MAHLKÖNIG Customer Services or a representative authorized by MAHLKÖNIG! This will be an opportunity for thorough familiarization of your service staff with the machine's operations.

NOTICE

Carrying out the start up yourself can lead to personal injury and damage to property and assets!

Installation check

- Has the mains cable been laid properly (without kinks and so it won't wear through abrasion and also won't present a trip hazard) and is it connected?

- Have all the cladding and covers been fitted?
- Has the bean hopper been attached correctly to the Coffee Grinder?
- Is the mains plug easily accessible?

8 Operation

This chapter contains all the information needed for safe operation of the Coffee Grinder.

8.1 Conditions for machine operation

Before the machine can be operated, the following conditions must first be satisfied:

- The machine has been correctly installed and connected as described in the chapter 6 entitled “Installing the machine”.
- The installation check has been carried out as described in the chapter 7 entitled “Start up”.

8.2 Operating

Operating the Coffee Grinder:

1. Use the adjusting knob (1) to set the desired grinding fineness. The scale ranges from 1 (Turkish) to 9 (Coarse).
2. Lift the cover (2) and pour the coffee beans into the bean hopper (3).

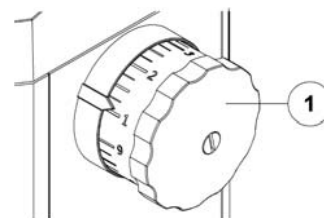

NOTICE

Only whole coffee beans may be loaded into the bean hopper. Do not put ground coffee into the bean hopper! Coffee that has already been ground once must not be loaded into the bean hopper and reground, since this will clog the grinding mechanism!

3. Close the cover (2).

4. Lift the clamping lever (5) and simultaneously place an empty bag over the spout (6). Always release the clamping lever before removing the bag.

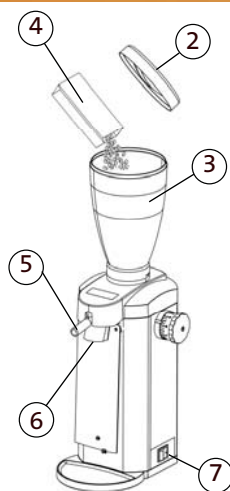

8. Keep hold of the bag, raise the clamping lever to the limit stop and release it. The lever returns to its initial position, thus ensuring that the spout is emptied correctly.

9. Repeat point 8 two or three times until there is no coffee powder stuck to the spout.

10. Keep hold of the bag and raise the clamping lever again in order to remove the bag.

8.3 Calibrating the machine

The machine is factory calibrated and supplied ready for operation. The scale on the adjusting knob is based on the factory setting and determines the fineness of the grind.

The factory setting can be changed if:

- The desired grind does not correspond to the fineness of the factory setting.
- An individual grind is desired.

NOTICE

Ensure that the bag is fully open before placing and fastening it over the spout! If the ground coffee cannot flow freely into the bag, it may result in clogging and malfunctioning of the Coffee Grinder!

5. Ensure that the hopper slider is open.

6. Start the grinding motor by setting the ON/OFF switch (7) to ON (I).

7. After grinding, always set the ON/OFF switch to "OFF" (0).

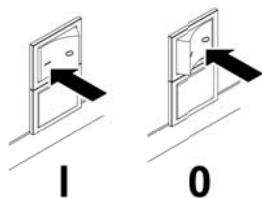
**NOTICE**

Changes to the factory setting should only be carried out by service staff!

Procedure:

1. Switch ON the grinder via the ON/OFF switch (I).
2. Hold the adjusting knob (1) and use a screwdriver to loosen the center screw (2), approx. 4 rotations.

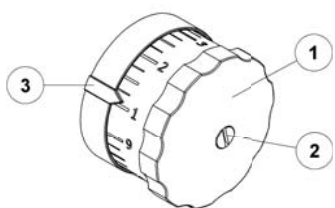

3. Turn the adjusting knob (1) clockwise until the limit stop.
4. Pull out the adjusting knob to disengage it from the limit stop and rotate it further. Subsequently release and push in the adjusting knob until it re-engages.
5. Turn the adjusting knob until you hear the grinding discs touching.
6. As soon as you hear the grinding discs scraping, turn the adjusting knob counter-clockwise the distance of 2 scale lines. This corresponds to the basic factory setting. Depending on the desired fineness of the grind, it is possible to turn the adjusting knob back further. This results in a coarser grind.
7. Pull out the adjusting knob again at this position and turn it until # 1 is aligned to the arrow (3). Push the adjusting knob back in at this position.
8. Hold the adjusting knob and tighten the center screw (2). Test grind the new setting.

NOTICE

The grinding discs should never touch at #1 setting! If the grinding discs are touching, repeat the setting procedure.

9 Maintenance

Careful and regular maintenance will ensure that your machine gives trouble-free service. This covers all the tasks which keep a functioning machine in good working order:

- Cleaning
- Replacing components

NOTICE

Ensure that maintenance work is only carried out by your service and maintenance staff or by MAHLKÖNIG Service partner since these tasks require specialist knowledge and particular skills. Neither can be obtained by reading these Operating Instructions.



The grinder must not be opened until the machine is completely at rest. Before opening the casing, pull the mains plug of the machine out of the mains socket!

We recommend that the machine be given a complete overhaul at least once per year.

Please feel free to call on MAHLKÖNIG Service partner for all maintenance work. Please refer to the chapter 14 entitled "Contact Addresses" for the address and contact numbers of Customer Services.

After approx. every 1,000 kg of ground coffee: Inspect grinding discs!

After one year of service: Overhaul of the whole machine!

9.1 Cleaning

HINT

Cleaning must be carried out by service staff!

NOTICE

Foreign material should not enter the grinding chamber!

- Always clean the machine if it gets dirty – in any case, at least once per week.

Cleaning agents

Items	Cleaning agents
Hopper Collecting tray	Do not use agents with an abrasive or scouring effect! Use food-grade, neutral cleaning agents which comply with hygiene regulations.
Spout outside	Use conventional cleaning agents for stainless steel.
Spout inside Grinding chamber Grinding discs Casing outside	Only clean with a dry cloth or brush!

HINT

Do not use any alkaline cleaning agents. Alkaline cleaning agents can impair the flavour of the coffee.

NOTICE

Do not use compressed air to blow off material from the machine and do not spray with steam or water! This could short-circuit and thus damage the machine.

9.1.1 Removing / Replacing the hopper

The bean hopper has to be removed to clean the grinding mechanism, grinding discs and spout.

HINT

If there are still coffee beans inside the bean hopper, push in the hopper slider into the hopper adapter. This prevents the coffee beans falling out when you remove the hopper.

If you are using a bean hopper without a slider, it is recommended to empty the hopper before removing it.

Procedure:

1. Disconnect the mains plug from the power outlet.
2. Use a (size 0) screwdriver to push the pin downwards and simultaneously rotate the bean hopper counter-clockwise.
3. Once the bayonet coupling has been released it is possible to lift up and remove the bean hopper.
4. Replacing the bean hopper is carried out in reverse order, but without pushing down the pin.

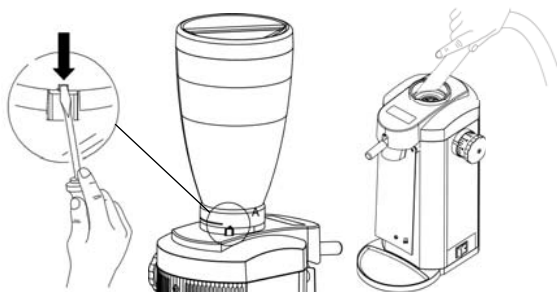
**NOTICE**

Use a vacuum cleaner to remove any coffee beans from the grinding chamber before replacing the bean hopper. The bayonet coupling has to be clean and free from foreign material in order for it to close correctly.

9.1.2 Cleaning the grinding mechanism

CAUTION

The grinding discs must not be removed until the machine is completely at rest! Before beginning this task, switch off the machine and pull out the mains plug from the mains socket.

Procedure:

1. Disconnect the mains plug from the power outlet.
2. Remove the bean hopper as described in section 9.1.1 "Removing / Replacing the hopper".
3. Lift and remove the cover plate (1) from the machine.

4. Use a (size 4) screwdriver to unscrew the 3 screws (2).
5. Remove the stationary disc flange (3) including the spout from the machine.
6. Clean the grinding discs (4) and remove any foreign matter. Please read section 9.1 "Cleaning".
7. Check the condition of the grinding discs and insert new ones if they are defective or worn.
8. Reassemble all the parts in reverse order.

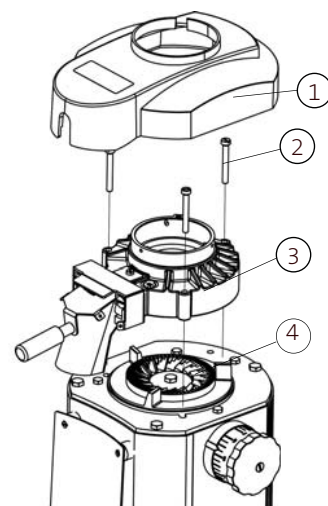

9. Replace the bean hopper as described in section 9.1.1 "Removing / Replacing the hopper".

HINT

Ensure that the mating surfaces are absolutely clean before reassembly! Failure to do so will result in inconsistent grinds.

10. Reconnect the grinder to the power supply after complete reassembly.
11. Turn the adjusting knob to coarse. In this way the discs cannot be damaged in case of wrong assembly.
12. Switch-on the grinder and slowly turn the adjusting knob to fine.

HINT

If the grinding mechanism jams or if you hear the sound of grinding discs rubbing against each other, re-calibrate the machine. For this, read section 8.3 entitled “Calibrating the machine”.

9.1.3 Cleaning the spout**Procedure:**

1. Disconnect the mains plug from the power outlet.
2. Remove the bean hopper as described in section 9.1.1 “Removing / Replacing the hopper”.
3. Lift and remove the cover plate (1) from the machine.
4. Use a (size 3) screwdriver to unscrew the screw (2) of the spout.
5. Lift up the spout (3) until both screw heads (4) fit through the opening. Subsequently remove the spout (3) towards the front.
6. Clean the spout and remove any foreign matter. Please read section 9.1 “Cleaning”.
7. Reassemble all the parts in reverse order.
8. Replace the bean hopper as described in section 9.1.1 “Removing / Replacing the hopper”.

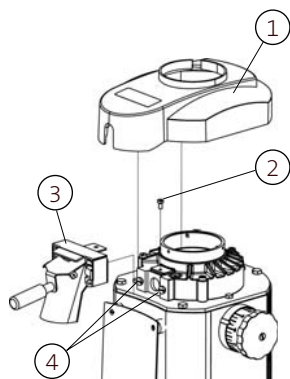
**HINT**

Ensure that the mating surfaces are absolutely clean before reassembly!

9. Reconnect the grinder to the power supply.

9.1.4 Cleaning the collecting tray

Clean the collecting tray daily if soiled. Please read section 9.1 “Cleaning”.

The collecting tray can be removed and re-placed without tools.

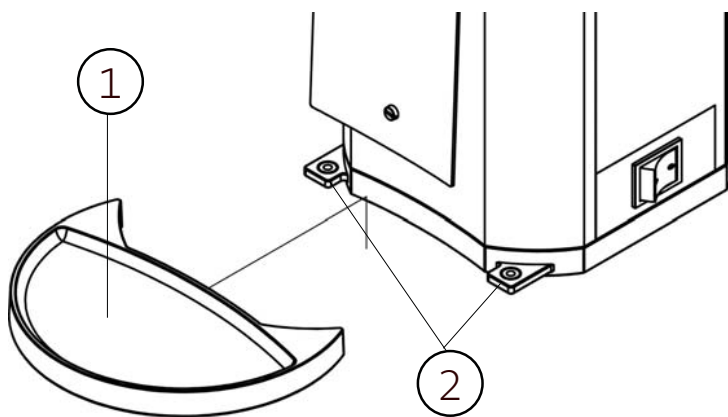

9.2 Replacing components

9.2.1 Replacing the grinding discs

When the grinding quality is no longer as desired, this means that the grinding discs need to be re-placed.



The grinding discs must not be removed until the machine is completely at rest! Before beginning this task, switch off the machine and pull out the mains plug from the mains socket.

Procedure:

1. Remove the stationary disc flange (1) according to the description in the section 9.1.2 "Cleaning the grinding mechanism" (steps 1-5).
2. Remove the grinding disc (2) from the stationary disc flange (1), and the grinding disc (3) from the rotating disc flange (4). The respective procedure is described in the next two sections.
3. Insert the new grinding discs.

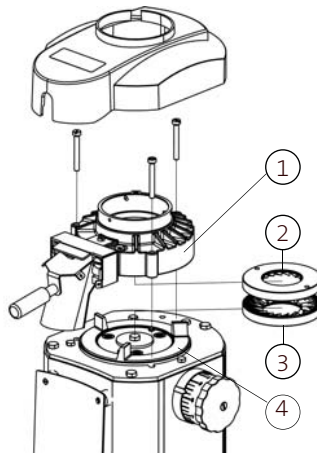

HINT

Ensure that the mating surfaces are absolutely clean before reassembly! Failure to do so will result in inconsistent grinds.

9.2.1.1 Removing the grinding disc in the rotating flange, without screws

Procedure:

1. Place a screwdriver (size 3) in the groove (1) at the grinding disc (2).
2. Rest the tip of the screwdriver on the facing edge and use it to lever the grinding disc.
3. Once the grinding disc has overcome the magnetic attraction, it can be removed manually.

Installation of the grinding disc is carried out in reverse order.

HINT

Ensure that the grinding discs are positioned correctly during installation. Observe the position of the driver!

HINT

Ensure that all the mating surfaces are absolutely clean before reassembly! Failure to do so will result in inconsistent grinds.

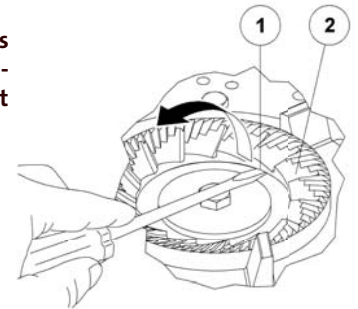

9.2.1.2 Removing the grinding disc in the stationary flange, without screws

Procedure:

1. Place a screwdriver in the groove (1) at the grinding disc (2).
2. Rest the tip of the screwdriver on the facing edge and use it to lever the grinding disc.
3. Once the grinding disc has overcome the magnetic attraction, it can be removed manually.

Installation of the grinding disc is carried out in reverse order.

HINT

Ensure that grinding discs are positioned correctly during installation. Observe the position of the driver!

HINT

Ensure that all the mating surfaces are absolutely clean before re-assembly! Failure to do so will result in inconsistent grinds.

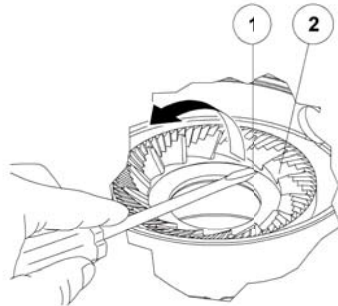

9.3 Maintenance work on the mains power supply

HINT

Work on current-bearing assemblies or components must only be carried out by MAHLKÖNIG technicians or by a qualified specialist electrician. Please see chapter 12 “Electrical wiring diagrams” for the circuit diagrams.



Only open the grinder when it is completely idle. Before opening the casing, switch off the machine and disconnect the plug from the mains socket.

10 Protection devices / Faults

10.1 Protection devices

The grinder is protected by a temperature monitor in the motor coil and equipped with additional over-load protection (Klixon). A micro switch integrated in the upper part of the machine prevents the motor from starting up if the cover plate or the bean hopper has been positioned incorrectly.

Temperature monitor

The temperature monitor switches the grinder off as soon as the motor coil is too hot. This can occur for example if the system is in continual use. After the grinder has cooled down, the machine is ready for service again.

Overload protection / Klixon

The overload protection is tripped if the current accepted by the grinder is too high. This can occur if the grinding discs are blocked.

If the short circuit protection has tripped, it has to be reset manually:

- Tilt the grinder slightly to the left.
- Press the button (1) on the bottom of the grinder and subsequently replace the machine in its original position.

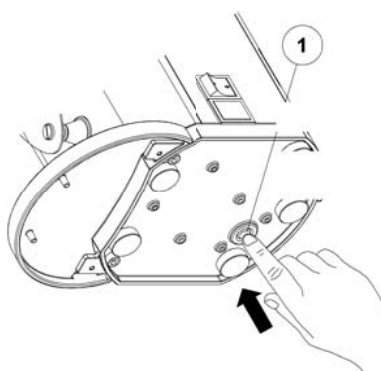

10.2 Faults

HINT

Ensure that customers using the equipment on a self-service basis are advised to call service staff in the event of a fault. Customers must not attempt to correct faults themselves by tampering with the machine.

We recommend placing a notice in the immediate vicinity of the machine as follows:

In the event of a fault please notify sales staff!

10.2.1 Fault correction

Fault	Indication	Corrective action
The grinder cannot be switched on	The grinder is not connected to the power supply	Check and, if necessary, connect the mains plug supply
	The overload protection / Klixon has tripped	Switch on the Klixon. Read section 10.1 "Protection devices"
	The overload protection / Klixon has tripped again	Check whether any foreign matter is blocking the grinding disc. Proceed as described in section 9.1.2 "Cleaning the grinding mechanism". Subsequently switch on the Klixon. Read section 10.1 "Protection devices"
	The building fuse has tripped	Check and, if necessary, switch on the fuse
	The cover plate has not been replaced or has been incorrectly replaced	Check and replace correctly

Fault	Indication	Corrective action
	The bean hopper has not been replaced or has been incorrectly replaced	Check and replace correctly
	The micro switch or casing cover is defective	Replace the micro switch or casing cover
The grinding motor is blocked	The grinding chamber is clogged	Clean the grinding chamber and the grinding discs. Read section 9.1 "Cleaning"
	The spout is clogged	Clean the spout. Read section 9.1.3 "Cleaning the spout"
Inconsistent grinding	The grinding discs are worn	Check the grinding discs for wear and, if necessary, replace them with new ones.
Increased dust	The grinding discs are worn	Check the grinding discs for wear and, if necessary, replace them with new ones.

11 Waste disposal

Consider such issues as environmental compatibility, health hazards, waste disposal regulations and the local facilities for disposal in compliance with regulations.

Waste disposal of the machine is the responsibility of the operator. He is responsible for disposing of the machine carefully and in compliance with the current local regulations. In particular, he must observe the following instructions:

Before dismantling the machine, all external connections must be broken.

Mains

- Pull out the mains plug from the mains socket and remove the mains plug from the electric cable.

HINT

Only the maintenance staff must be allowed to dismantle the machine.

When finally decommissioning the machine, proceed as follows:

- In compliance with regulations, dispose of hazardous materials as special waste.
- Separate out parts made of plastic and dispose of them for recycling.
- Pre-sort metal parts and separate them ready for shredding or scrapping.

12 Electrical wiring diagram 200-230V / 50Hz

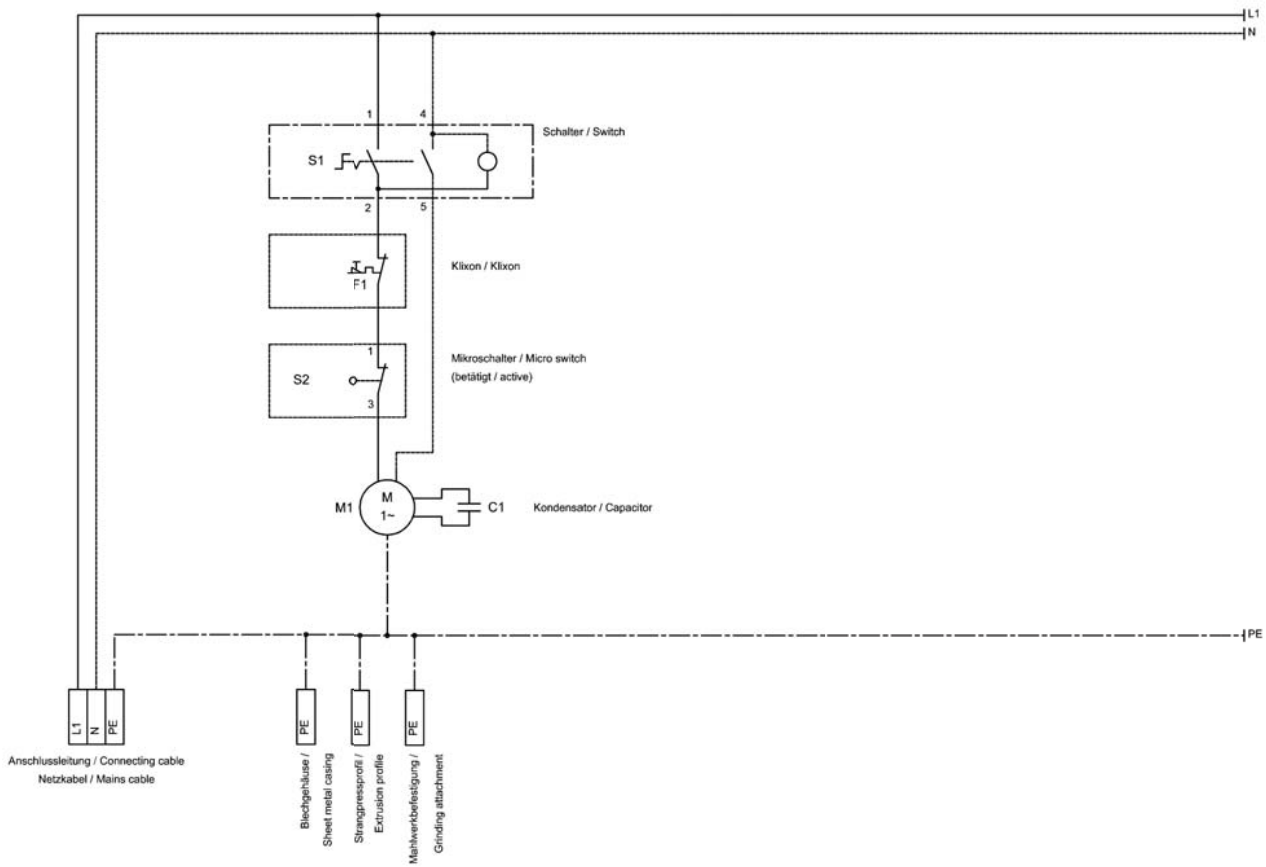

12 Electrical wiring diagram 100-115V / 60Hz

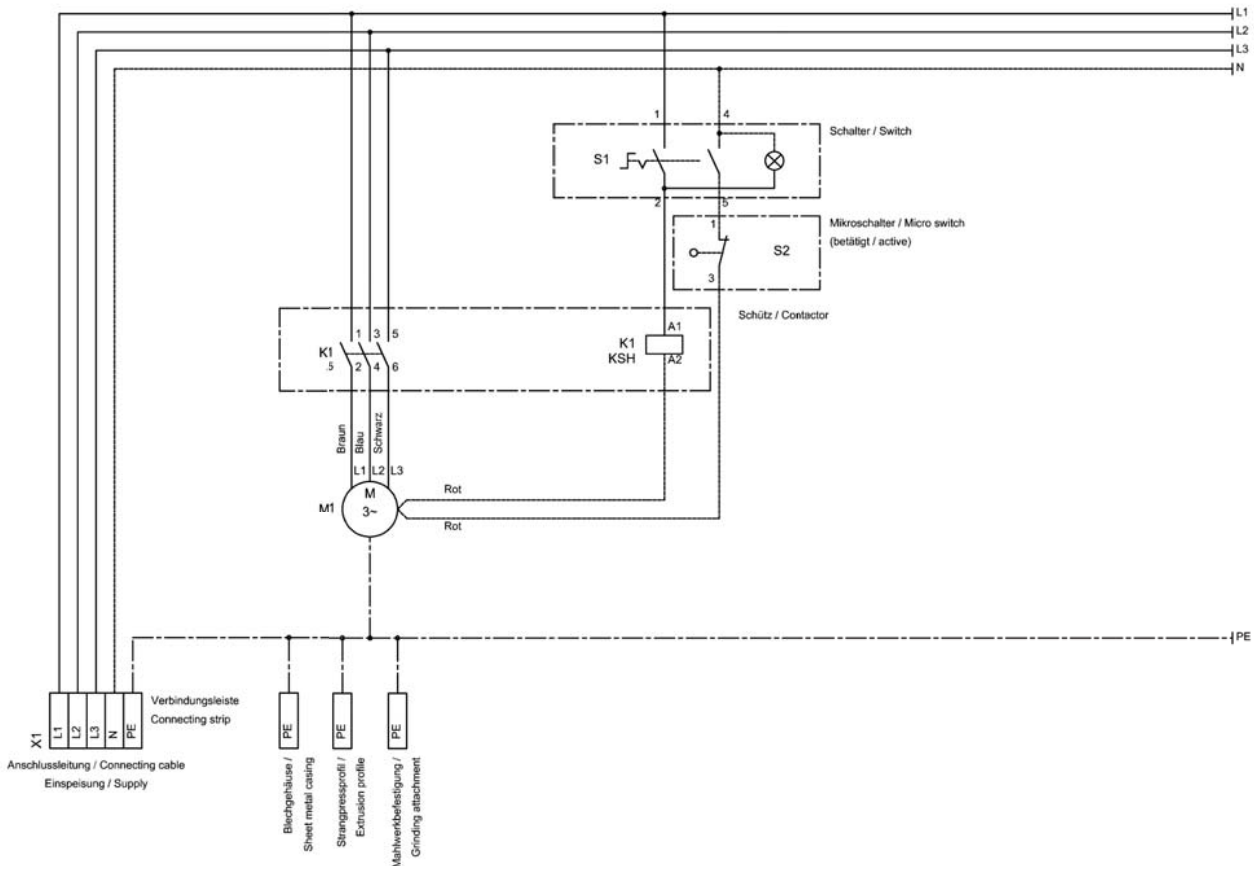

13. Warranty Conditions

1. The warranty period is 1 year from the date of purchase.
2. The warranty covers all damages that can be attributed to inferior materials or defective workmanship. Corresponding grinders will be repaired or replaced free-of-charge, with the exception of transport or freight charges. Transport is the responsibility of the customer. Therefore, avoid damages with all returns by correct packing.
3. The grinder may only be opened for cleaning purposes in accordance with the Operating Instructions.
4. This warranty does not cover damages which have occurred through: Improper usage, improper maintenance, lack of servicing, usage for purposes other than those intended, incorrect installation, incorrect voltage, breakage, natural wear or for reasons beyond our sphere of influence.
5. In order to maintain the warranty, only original spare parts and accessory parts may be used.
6. Observe in addition our General Delivery Conditions in their respective current version.
7. The manufacturer is in no way liable for consecutive or secondary damages.
8. The warranty does not cover costs emerging from repairs conducted by non-authorized personnel.

14 Contact addresses

Customer Services

If maintenance work reveals that the grinding discs need re-sharpening or replacing, or that other repairs are necessary, please contact your nearest Service Partner.

New grinding discs and spare and accessory parts (including parts for models modified since purchase) can be ordered from our Customer Services or from the responsible agent.

For rapid and appropriate advice and deliveries of grinding discs, spare and accessory parts, always supply the information shown on the Coffee Grinder nameplate, i.e. serial number and type of power supply.

Sales and Service partner are provided on:
www.mahlkoenig.de



Notes



Notes



Notes

MAHLKÖNIG GmbH & Co. KG

Tilsiter Straße 142
D- 22047 Hamburg, Germany

Tel.: +49 (0)40 / 69 69 40-0

Fax: +49 (0)40 / 69 39 721

office@mahlkoenig.de ; www.mahlkoenig.de

November 2009

Subject to be changed without prior notice!!



The professional art of grinding
since 1924