

manual

swift eps_b

The Swift grinder is the only grinder that grinds and tamps on demand, with no waste and no mess, to an accurate volumetric dose.

Swift's clever engineering and design guarantee level and consistent coffee beds, time after time. Flat ceramic burrs ensure minimal heat buildup during the grinding process. Compatible with all La Marzocco espresso machines. Swift is ideal for high volume locations where consistency is key. Swift technology maintains quality in the cup, shot after shot, no matter who is using it.



la marzocco

handmade in florence

swift eps_b

Operating Manual V2.1 - 11/2014

Chapters

1. Introduction	page 3
2. Components	page 3
3. Specifications	page 4
4. Installation	page 5
5. Engaging the Portafilter	page 6
6. Operating the SWIFT EPS _B	page 7
6.1 SWIFT EPS _B	page 7
6.2 SWIFT S/D	page 7
7. Adjusting Coffee Grind	page 9
8. Adjusting Dose Quantity	page 10
8.1 SWIFT EPS _B	page 10
8.2 SWIFT S/D	page 11
9. Daily Cleaning	page 15
10. Impeller	page 18
11. Burr Change-Out	page 20
12. Chute Clean-Out Tool	page 24
13. Fuse Replacement and Reset Switches	page 25
14. Tips and Troubleshooting	page 27
15. Electrical Diagrams	page 29
16. Cleaning Procedure	page 31
17. Recycling	page 32



la marzocco

handmade in florence

La Marzocco S.r.l.

Via La Torre 14/H
Località La Torre
50038 Scarperia e San Piero
(Firenze) - ITALIA

www.lamarzocco.com
info@lamarzocco.com

T: +39 055 849 191
F: +39 055 849 1990

EN

certifications available:



1. Introduction

Espresso Preparation System

Congratulations on choosing the SWIFT EPS_B from La Marzocco. Your application of this new product in your café or home will result in a number of important benefits to you.

Quality, Consistency, Conservation, and Speed.

Your new SWIFT EPS_B grinds, doses and tamps coffee directly into the portafilter, eliminating the need to do this manually. It measures and doses by volume, not

time, so waste and product inconsistency are reduced. At the same time, the SWIFT EPS_B enhances coffee freshness by grinding coffee by dose, not by bulk. This manual includes information about how to maintain and troubleshoot

your SWIFT EPS_B for optimal performance.

Please review it carefully.

2. Components

Verify that all parts are included when you receive your new SWIFT EPS_B.

- a. Grinder
 - b. Two bean hoppers and lids
 - c. Drip tray
 - d. Fuse pulling tool
 - e. Screwdriver
 - f. Cleaning brush
 - g. 22 mm. Portafilter baskets
 - h. Tamper cover lid
 - i. Fuses (inside tamper cover lid)
 - j. Long-arm L-key 3/32 hex size
 - k. Grinder discharge clean-out tool
- Manual
Warranty and registration card

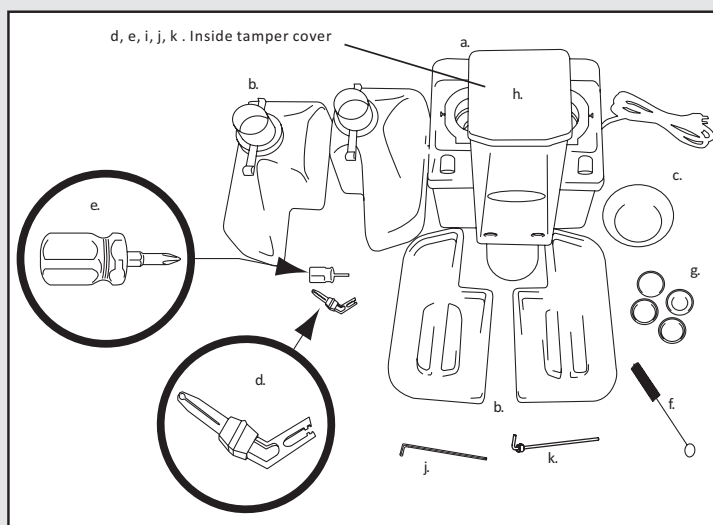

3. Specifications

Height	65.5 cm/25.8 in.
Width	35 cm/13.8 in.
Depth	36 cm/14 in.
Shipping Weight	31 kg/68 lbs.
Voltage	Single phase 220 VAC or Single phase 110 VAC
Amperage	7.5 amps, 220 VAC or 15 amps, 110 VAC
Bean Hopper Capacity	1.8 kg/4 lbs. each
Watts	780 W

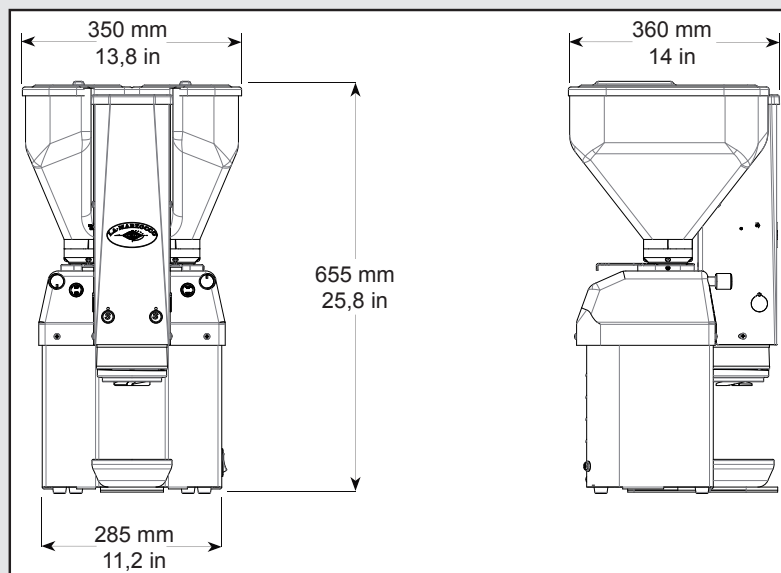

4. Installation

The SWIFT EPS_B is easy to install.

However, there are several important considerations to keep in mind. The SWIFT

EPS_B requires a grounded 110v, 15 amp (or 220v, 7.5 amp) power supply. It also requires a minimum 16" x 16" (406 mm x 406 mm)

space on the counter. Since the unit is 26" (660 mm) in height, allow at least 30" (762 mm) of vertical clearance so there is sufficient space to

allow the easy removal of the bean hoppers and lids. The SWIFT EPS_B weighs about 75 lbs (34 kg), so make sure your counter will support this.

- (1)** Install the bean hoppers and tighten the safety screws.

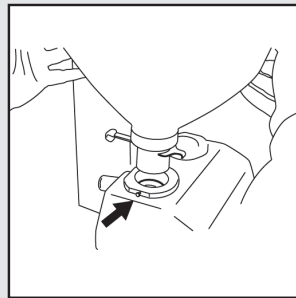

- (2)** Plug the SWIFT EPS_B into a grounded 110v or 220v single phase power supply.

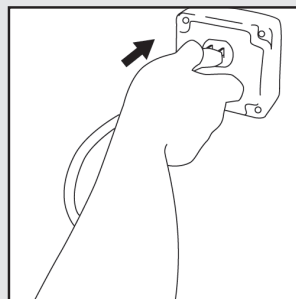

- (3)** Pour coffee into the bean hoppers. Leave space above the SWIFT EPS_B.

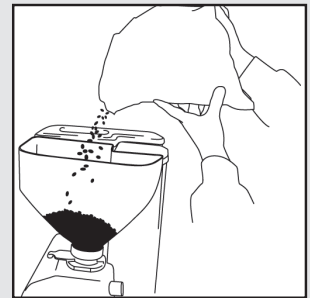

- (4)** Open the bean gates.

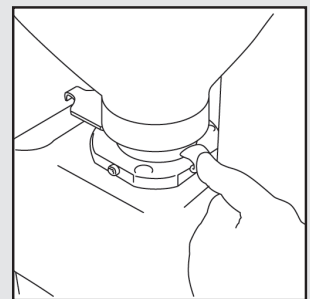

- (5) Turn on the grinder by engaging the main power switch. The red light will come on.

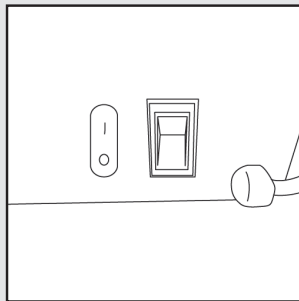

5. Engaging the Portafilter

The portafilter engages directly to the SWIFT EPS_B. Since the SWIFT EPS_B has no watertight seal, it is

not necessary to force the portafilter into place. Engage the portafilter with only a light amount of force. If the

grinder shifts on the counter top, you are using too much force.

Engage portafilter gently.

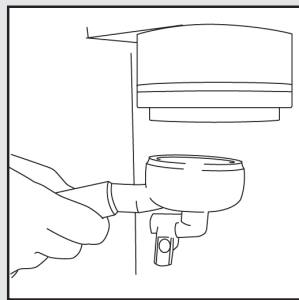

There is no need to force it into position.

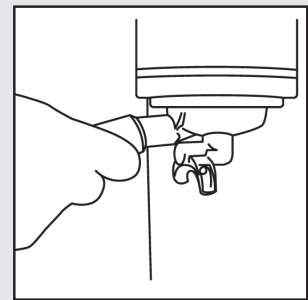

6. Operating the SWIFT EPS_B

6.1 SWIFT EPS_B

Once the portafilter is engaged, press one of the start buttons located at the front of the SWIFT EPS_B. The right and left buttons correspond to the right and left bean hoppers. Coffee will

Select the right or left bean hopper.

be ground, dosed, and tamped from one of these locations, depending on which button you press. The red indicator lights located above the start buttons are illuminated when the SWIFT EPS_B is grinding and tamping. Once

the red light corresponding to the button selected is no longer illuminated, you may remove the portafilter from the SWIFT EPS_B and engage it into the espresso machine. The SWIFT EPS_B tamps the coffee as it is ground. When

the volume of ground coffee in the portafilter reaches the set level, the grinding motor turns off. The tamping motor continues to run for 1-3 seconds, "polishing" the tamped coffee.

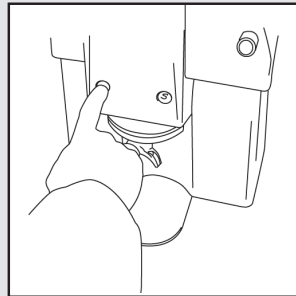

Remove prepared portafilter.

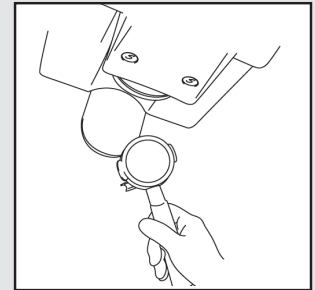

6.2 SWIFT S/D

The SWIFT is now available in a Single/Double dose version which permits dosing and tamping into specific filters for either single or double doses.

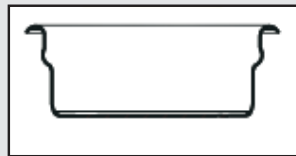

DOUBLE L115/A/S

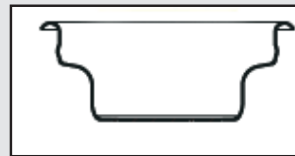

SINGLE L116/A/S

Externally this model appears like the standard version, but the internal impeller, which deposits and presses the coffee, is smaller in diameter so that it does not get stuck inside a single filter.

To dose and press coffee when using a double filter, there is a cushioning cylindrical ring next to the external circumference of the impeller (see image here below).

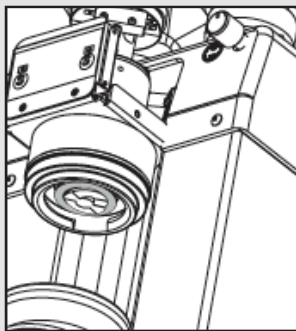

standard filters that are normally supplied with espresso coffee machines or with standard Swift models (double only).

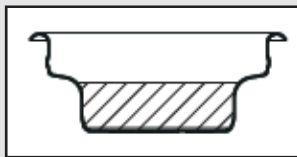
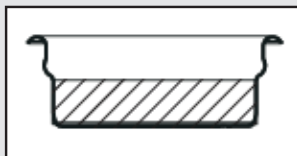

Using the S/D SWIFT

The S/D Swift grinder is activated by pressing the "S" switch ONCE to prepare a single filter (L115/A/S), and TWICE in a row to prepare a double filter (L116/A/S).

As previously explained, the filters used for the SWIFT EPSB are different from the

The filters designed for this specific model of the SWIFT have a different placement of holes than standard filters. This difference makes it possible to obtain an elevated quality in the consistency of brewing in spite of a grinder-doser with automatic tamping.

Flashing indicator lights

The red indicator lights will flash for a number of reasons. These are summarized below:

- You attempted to start the process with a full portafilter.
- The safety timer has run out due to an empty beanhopper, a closed bean gate, or a plugged bean hopper chute.
- There is no portafilter engaged in the SWIFT EPSB.

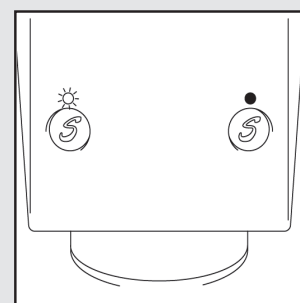

Blinking indicator lights relay information.

SWIFT S/D

- In version SWIFT S/D the red indicator lights will flash when working the grinder for a double doses.

7. Adjusting Coffee Grind

To achieve your desired brew time and coffee consistency, a manual adjustment can be made to the grinder to modify the grind of the coffee. (The tamping pressure is not adjustable and remains constant). Rotate the adjustor knobs as described below.

- (1)** Locate the grinder adjustor knob that corresponds to the left or right side of the grinder.
- (2)** Grinding the coffee more finely will result in a slower pour. To achieve a slower pour, adjust the knobs as follows:
Left bean hopper: Turn the knob counter-clockwise.
Right bean hopper: Turn the knob clockwise.
- (3)** Grinding the coffee more coarsely will result in a faster pour. To achieve a faster pour, adjust the knobs as follows:
Left bean hopper: Turn the knob clockwise.
Right bean hopper: Turn the knob counter-clockwise. When making this adjustment, remember to turn the knob in a minimum of half-turn increments. Brew one or two shots to test the adjustment.

Note: There are many variables that can affect coffee, including temperature, humidity, and freshness of the roast. All of these can cause slight variations in shot times.

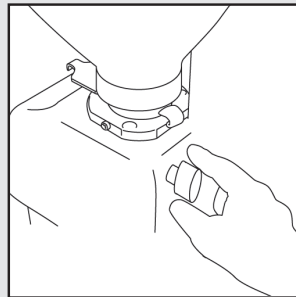

Adjust coffee grind

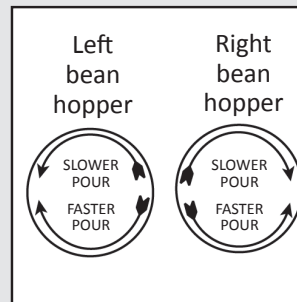

8. Adjusting Dose Quantity

8.1 SWIFT EPS_B

The SWIFT EPS_B is set to dose approximately 16 to 18 grams of coffee in 22mm basket

provided with the grinder. It is possible to change the dosage quantity by raising or lowering the height of the impeller. Additionally, the

SWIFT EPS_B is able to dose different quantities using other baskets, available through your retailer.

▲ WARNING ▲
HAZARDOUS VOLTAGE
DISCONNECT FROM POWER
SUPPLY BEFORE SERVICING

- (1) Remove the tamper cover as described on page 19.

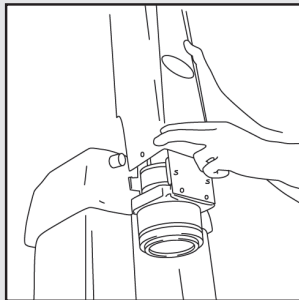

Lift off cover

- (2) Using the long-arm 3/32 hex-size L-key, loosen the set screw in the collar of the tamper shaft coupling.

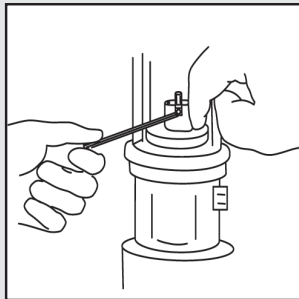

Loosen set screw

- (3) Holding the tamper shaft coupling in place, rotate the impeller in the direction desired.

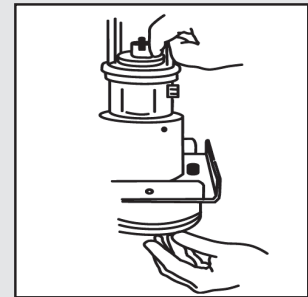

Hold tamper shaft
coupler and rotate
impeller

- (4) To increase the dosage amount, turn the impeller clockwise, as viewed from below. To decrease the dosage amount, turn the impeller counter-



Increase the dosage

- (5) Ensure that the set screw is against the flat side of the tamper shaft. Retighten the set screw in the collar of the tamper shaft coupling.

- (6) Reassemble.

clockwise, as viewed from below.

Note: One 360° turn is equal to approximately 1 gram of coffee.

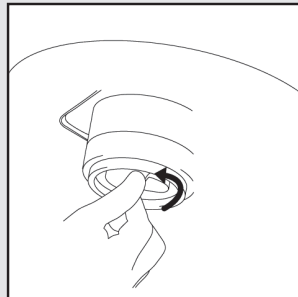

Decrease the dosage

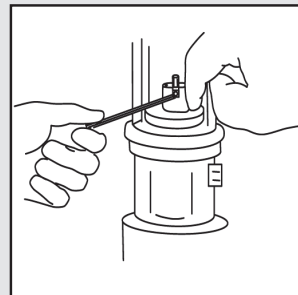

Retighten set screw

8.2 SWIFT S/D

Key to performance:

The 3 figures here show how the Single/Double SWIFT operates.

Coffee drops through the channels linked to the burrs inside the dosing chamber where it is deposited and tamped in layers by the impeller until obtaining, one layer at a time, the required amount.

Single filter:

The coffee is deposited and pushed downward, therefore tamped in a uniform manner by the impeller.

The setting of the time for grinding will determine the amount of ground coffee ready for extraction.

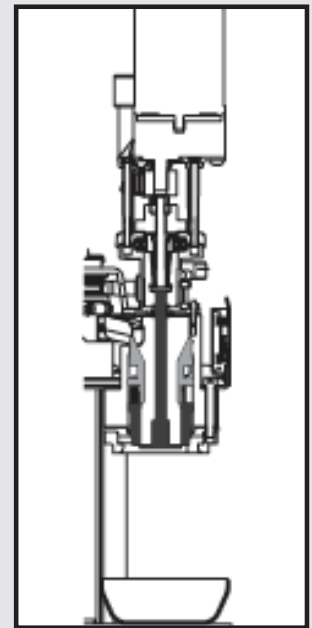

Double filter:

The coffee is deposited and then tamped in a uniform fashion by the impeller and

the cushioning cylindrical ring, whose springs push downwards with the same force as the impeller. The quantity in this case is

determined by the volume of ground coffee that pushes the shaft upwards, which, at the end of the process, will arrest the motors of the grinder

and tamper through a switch connected to an electronic board.

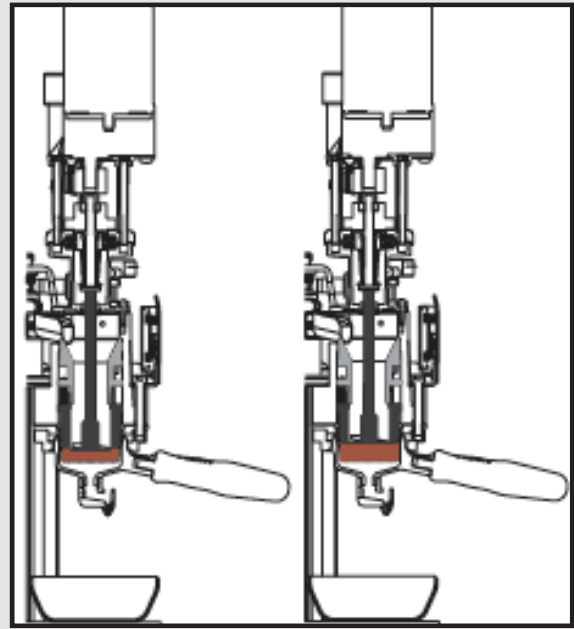
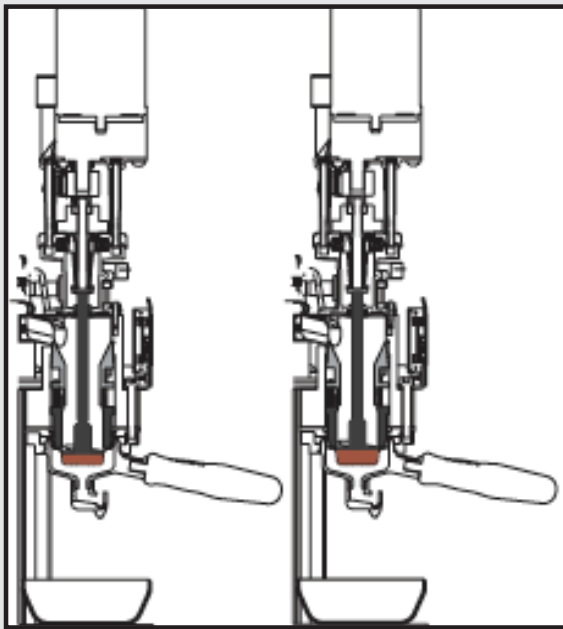

Setting up the Swift Grinder S/D

Regulation of single and double doses: to establish the doses on this specific grinder it is necessary to read through the procedures for the standard SWIFT under the section **“Regulation of quantity for dosing”** as well as follow these procedures.

BOTH MOTORS AND HOPPERS CAN DELIVER SINGLE AND DOUBLE DOSES

It is mandatory to proceed as follows:

Double dose:

- 1) Turn off the machine and remove the front tower cover to access to the screws that fix the shaft of the impeller.
- 2) Set the quantity of the coffee in the filter as on the standard SWIFT model. (see image A)
- 3) Adjust the grind (double):

adjust the grind to extract 60ml in 25 seconds.

- 4) Set the height of the cylindrical ring: the cylindrical ring next to the impeller should be at a height that allows to obtain a coffee puck surface that is completely even.

NOTE: The regulation of the height of the cylindrical ring (moveable part or tamper) is carried out by rotating the part clockwise to lift the ring and rotating it counter clockwise to lower.

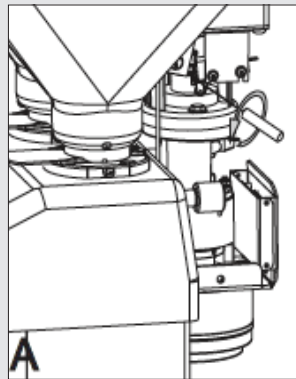

The cylindrical ring is held in place by two brass screws (see image B) so that the vibrations caused by the rotation of the impellers do not alter its position.

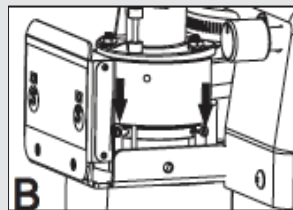

Remove the two screws and manually rotate the part, grasping it from the bottom.

The distance between the impeller and the cylindrical ring can vary from a minimum of 4 mm to 6 mm, a length that permits to obtain a perfectly even coffee puck (see picture below).

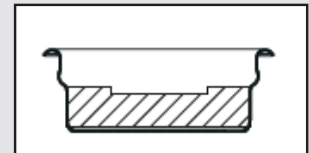

Lower ring (clockwise)

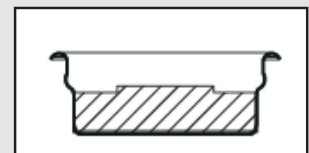

Raise ring (counterclockwise)

Single dose:

The quantity of coffee for the single dose is regulated by time.

By turning the screw at the left blue trimmer positioned at the back of the keypad it is possible to vary the grinding time.

Turning the screws clockwise, the time increases, increasing the dose.

Turning them counter clockwise, the time decreases, decreasing the dose.

This model of the grinder supplies a double dose that can be set between 15 and 17 gr and a single dose that can be set between 7,5 and 8,5 gr.

1) Before setting up, test the single dose:

- a) if extraction timing of 30 ml of espresso is less than 25 seconds, increase gram dose by rotating trimmer clockwise.
- b) if extraction timing of 30 ml of espresso is more than 25 seconds, decrease gram dose by rotating trimmer counter clockwise.

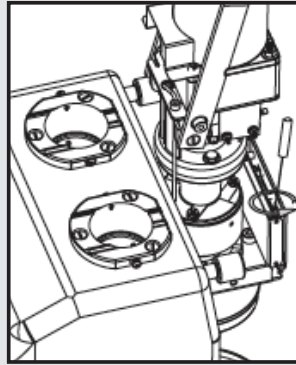
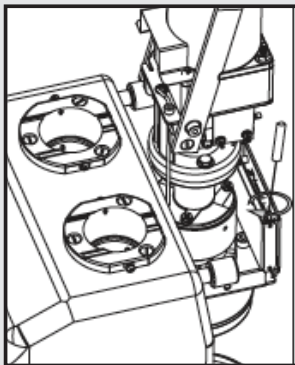

9. Daily Cleaning

Daily cleaning of the SWIFT EPS_B is important to the quality of your coffee beverages and to the mechanical life of the equipment. When the

cleaning instructions are carried out each day, there will be little chance of old coffee residue spoiling the flavor of your espresso drinks, or interfering with the

mechanical operation of your machine. There are three areas that must be cleaned: the bean hoppers, the burr chamber, and the impeller.

▲ WARNING ▲
HAZARDOUS VOLTAGE
DISCONNECT FROM POWER
SUPPLY BEFORE SERVICING

Bean hoppers and burr chamber

- (1) To clean the bean hoppers, close the bean gate to stop the flow of coffee beans to the grinding burrs.
- (2) Grind coffee into the portafilter to clear the remaining coffee. This may require two doses.

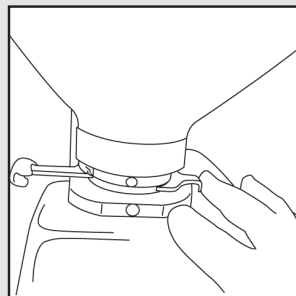

Close the bean gate

- (3) Disconnect the SWIFT EPS_B from its power supply.

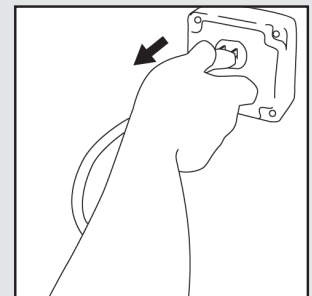

Disconnect

- (4)** The bean hoppers are locked into position by safety screw. Loosen the safety screw and lift the bean hopper from its mount.

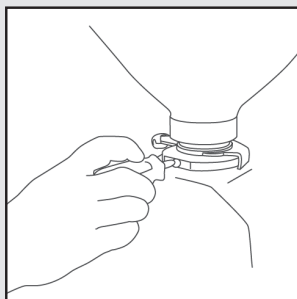

Loosen safety screw

- (6)** With a small brush, clean the burr chamber.

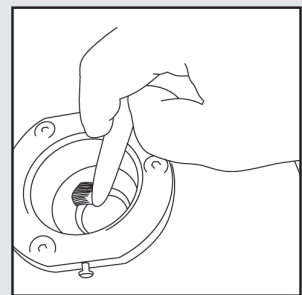

- (5)** Lift the bean hopper from its position. (Hold the bean gate closed while removing the bean hopper.)

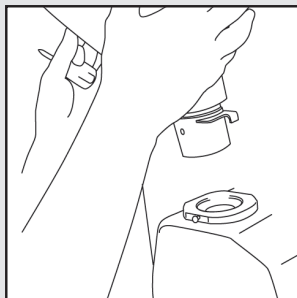

Remove bean hoppers

- (7)** Vacuum coffee fragments and loose grounds from the burr chamber.

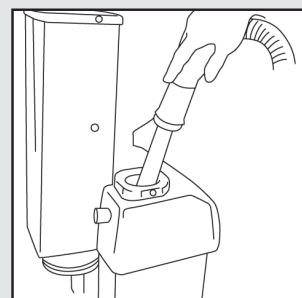

Vacuum

- (8) Wipe the inside of the bean hopper with a soft cloth to remove coffee oils.

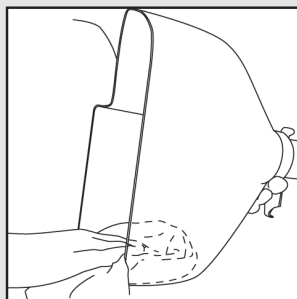

Strofinare

- (9) Repeat for both right and left bean hoppers.

- (10) Reassemble unit.

Do not operate without bean hoppers in place and safety screws tightened.

▲ WARNING ▲
DO NOT OPERATE WITHOUT
BEAN HOPPERS IN PLACE AND
SAFETY SCREWS TIGHTENED

10. Impeller

▲ WARNING ▲
HAZARDOUS VOLTAGE
DISCONNECT FROM POWER
SUPPLY BEFORE SERVICING

- (1) Disconnect the SWIFT EPS_B from its power supply.

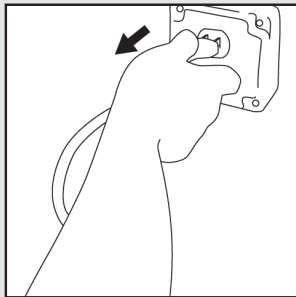

- (2) Lift off the tamper cover lid.

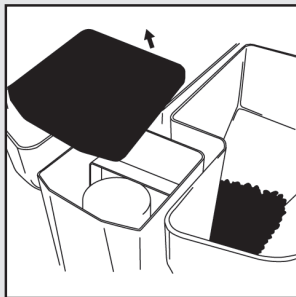

Tamper cover lid removal

- (3) Press and hold the shaft lock to prevent the shaft from turning.

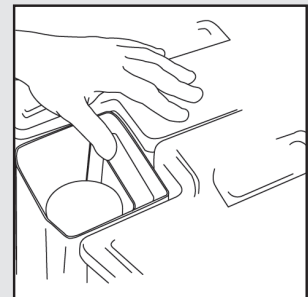

Hold shaft lock firmly

- (4) With your thumb and forefinger, press against the impeller flats. Turn the impeller clockwise, as viewed from below, to remove.



Remove the reverse-threaded impeller

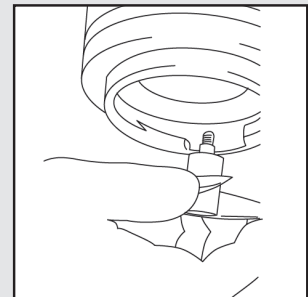

- (5) With the impeller out, clean around the bayonet ring with the brush and wipe loose grounds from this area. Insert the cleaning brush into the coffee collection area above the impeller and again wipe loose grounds away. Clean the impeller with a soft, dry cloth.

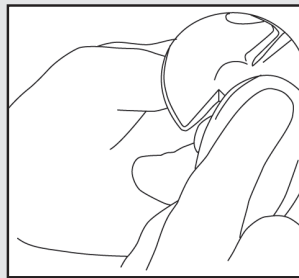

Clean impeller

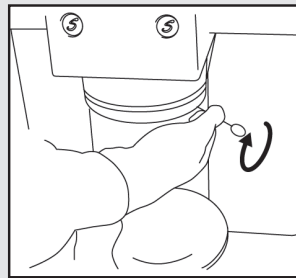

Clean portafilter engagement

- (6) Reinstall the impeller by turning counter clockwise.
- (7) Reconnect the SWIFT EPS_B to its power supply.

11. Burr Change-Out

Periodic burr replacement is required. While the ceramic burrs used in the SWIFT EPS_B have a much longer life expectancy than normal

steel burrs, it is still necessary to watch your coffee for the tell-tale signs of burr wear. These signs include inconsistent shot extraction

times, and the absence of noticeable change in your espresso when adjustments are made to the grinder.



- (1) Close the bean gates and grind out remaining coffee.
- (2) Remove both bean hoppers (see pages 13-15).
- (3) Remove the four screws holding the tamper cover in place, and lift off the tamper cover.

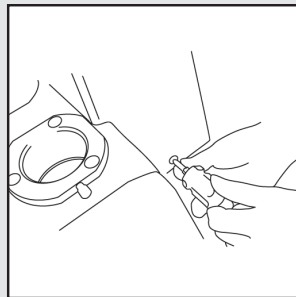

Remove lower screws (2)

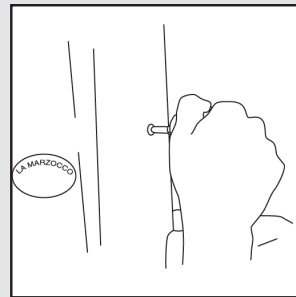

Remove upper screws (2)

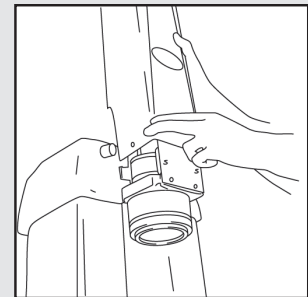

Lift off cover

- (4) Slide the two grind adjustor knobs from the shafts.

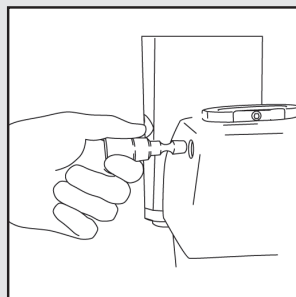

- (5) Remove the four perimeter grinder cover screws. Lift off cover.

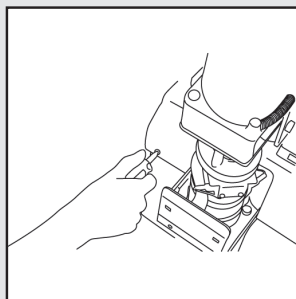

Remove screws

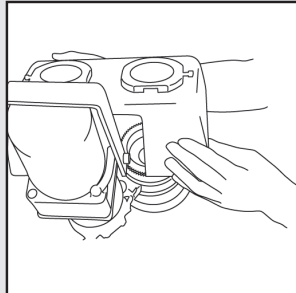

Lift off cover

- (6) Remove adjustor clamp from grinder head and remove adjusting mechanism.

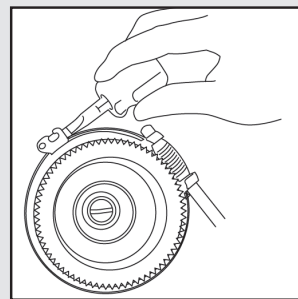

Loosen adjustor clamp

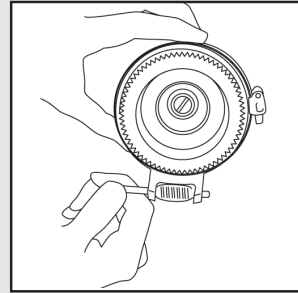

Remove adjusting mechanism

(7) Rotate burr collar several revolutions counterclockwise, until free.

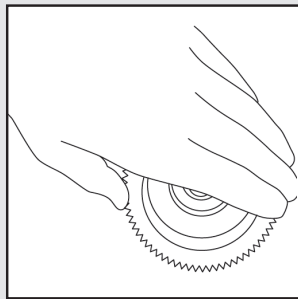

Rotate

(8) Remove the three burr mounting screws from both upper and lower burrs.

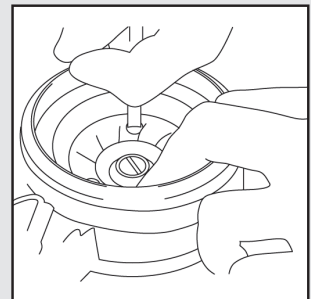

Remove lower screws

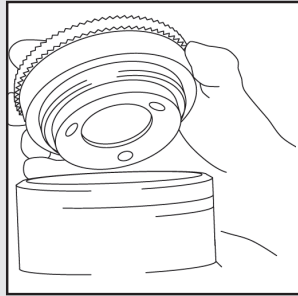

Lift off

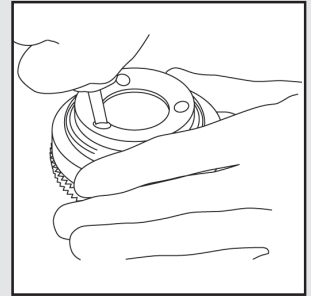

Remove upper screws

(9) Clean burr engagement surface with a towel or brush.

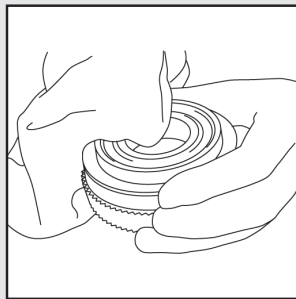

Wipe clean

(11) Install new burrs. Do not over-tighten screws, and be sure no debris is left under the burrs.

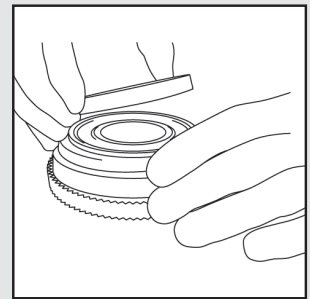

Position burr

(10) Vacuum the burr chamber.

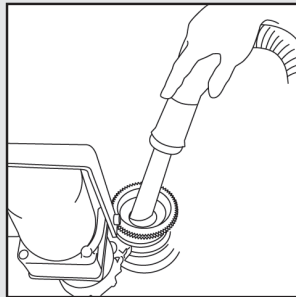

Vacuum

(12) Reassemble. Use a small amount of food grade grease on the upper burr mount threads when reinstalling.

12. Chute Clean-Out Tool

Occasionally the chute between the grinders and tamping chamber may become clogged, causing the fuse (resettable or replaceable) to trip. In addition

to replacing or resetting the fuse, it is important to remove the clogged grounds. On machines with serial numbers above 656, a chute clean-out tool is included.

This tool is used to loosen compacted grounds and alleviate clogging.



- (1) Clean out the hoppers and burr chambers as described on pages 13-15.

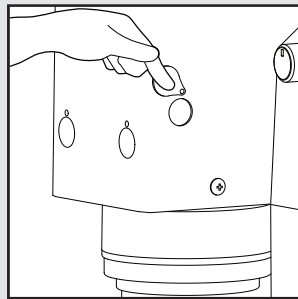

Lift off cover

- (2) Remove tamper cover as described on p. 18.
- (3) Find the holes located on either side of the lower grounds chamber.
- (4) Insert the long end of the clean-out tool into the hole. Repeat on other side.
- (5) Reassemble machine.

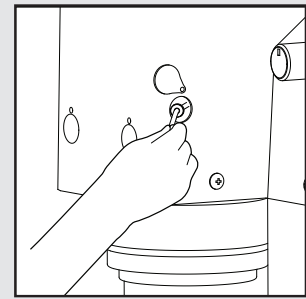

Insert tool into chute hole

13. Fuse Replacement and Reset Switches

The Swift EPSb has four fuses located at the rear of the machine behind the removable panel. These correspond to each of the grinder motors, the tamping motor, and the electronic controls. Occasionally it may be necessary to replace a fuse. When switching fuses

be sure to use only correctly rated replacement fuses. Electronics = 1 ea. @ 125m amps (normal); motor, grinder = 2 ea. @ 10 amps GDC; motor, tamper = 1 ea. @ 1 amp GDC. On machines with serial numbers 656 and higher, the 10 amp motor fuses are

replaced with reset switches on the exterior of the grinder. The head of the switch will protrude when it needs to be reset.

Note: See page 31-32 for fuse sizes and locations.

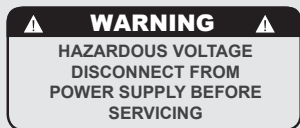

- (1) Disconnect the SWIFT EPSb from its power supply.
- (2) Access the fuse area by removing the two screws located at the lower part of the rear panel door. Do not remove the ground wire screw on the rear panel door.
- (3) Pull the panel door down and away, then unplug the ground wire, to expose the control electronics.

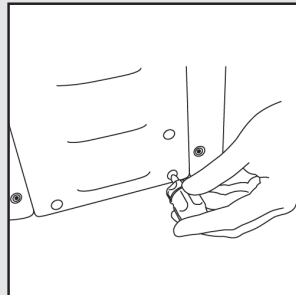

Remove screws (2)

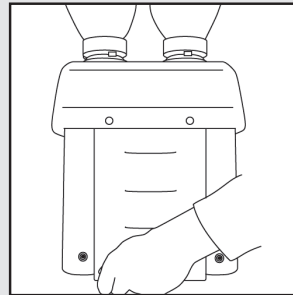

Pull down

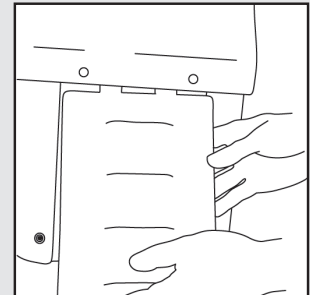

Pull out

(4) Remove the fuse using the tool provided. Note: A damaged fuse is identifiable by a broken filament and discoloration of the fuse glass.

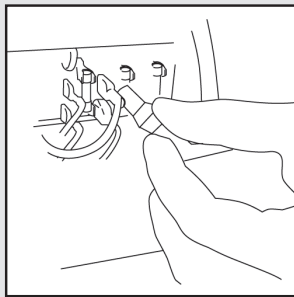

(5) Replace the damaged fuse with the correctly rated fuse. (See electrical schematic, page 31-32)

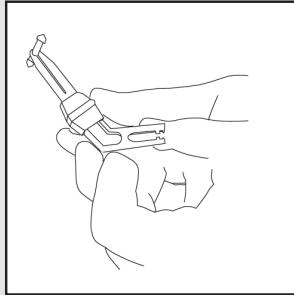

(6) Replace cover and screws.

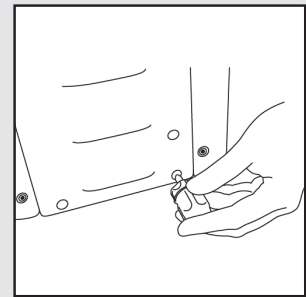

Replace cover

(7) Reconnect power.
Turn on and resume use.

14. Tips and Troubleshooting

What is the ideal shot time?

Shot time varies with all roasts and brew temperatures used to brew espresso. Most likely, a minimum shot time is 18 seconds and a maximum is somewhere in the 30 to 35 second range. The ideal brew time for your coffee depends on the coffee roast and dose size. It is a relationship of bean solids and oils plus tamping pressure and brew water temperature. Most of all, personal taste preference should control shot time.

After brewing, re-engage the portafilter in the group. Temperature stability at the portafilter will result in more

consistent pour times. The portafilter mounting area is a source of heat which can benefit the brewing process when used to keep the portafilter at temperature.

Clean groups and portafilters daily.

Clean espresso contact surfaces (screens and inserts) will result in better flavored coffee.

Limit rinsing from the grouphead to one second or less. Excessively rinsing the portafilter reduces the amount of hot water available for brewing. An infusion of cold water into the brewing

vessel may temporarily lower water temperature below the desired level. Since rinsing is usually undertaken as a way to clean the portafilter, consider wiping the portafilter instead. If you must rinse, do so with as little water as possible.

Watch the espresso you are brewing. Although making espresso is partly a mechanical process, the outcome is determined by organic factors like the coffee, the weather, the water, and your ability to balance these. Defining and adhering to a set of fixed parameters like brew time and shot size helps to ensure a beautiful shot.

However, ultimately the look and taste of the espresso is the final arbiter of a shot's acceptability. You must determine when everything is just right.

TROUBLESHOOTING GUIDE (* Items are for techs)

Message	Message Solution
Push start buttons and NOTHING happens.	<ul style="list-style-type: none"> - Check that the electrical plug is fully inserted - Switch the on/off switch to the on position (the light should be lit) <p>*Check fuses.</p>
Push the start button and the LIGHTS FLASH	<ul style="list-style-type: none"> - The portafilter is not fully engaged- The portafilter is already full - The tamper is stuck in the full or up position (see tamper cleaning instructions) - The safety timer has run out due to an empty bean hopper, closed bean gate, or a plugged bean hopper chute. <p>*Safety micro-switch faulty *Safety micro-switch rod is not contacting the switch properly.</p>
Grind TIME OUT is reached before basket is full.	<ul style="list-style-type: none"> - Check that the bean hopper gate is fully open - Grind coarseness may be too fine - Check passage below bean hopper for obstructions <p>*Adjust grind time reostat.</p>
One GRINDING MOTOR does not run (serial numbers 0-655)	<ul style="list-style-type: none"> - Check for blown fuse (see manual under fuse replacement) - If a grinder motor fuse is blown replace it with a 10 amp GDC fuse - Before starting the grinder motor remove the bean hopper (see manual) and ensure that the motor spins freely. If it does not spin freely follow the burr chamber cleaning instructions and look for foreign objects: nail, paper clip, rock, penny, etc.
One GRINDING MOTOR does not run (serial numbers after 656)	<ul style="list-style-type: none"> - Press the reset button that corresponds with the motor that does not run - If the reset button pops out again, turn the grind adjust knob 4 rotations in the faster pour direction, insert the clean out rod (see manual) remove the clean out rod, and restart the grinder. - If the reset button pops out again, remove the bean hopper (see manual) and ensure that the motor spins freely. If it does not spin freely follow the burr chamber cleaning instructions and look for foreign objects: nail, paper clip, rock, penny, etc. - Do not attempt to reset the breaker more than twice as this action may overheat and damage the triac on the main power board. <p>*Swap the power leads between the two motors to troubleshoot motor and triac.</p>
Shot gushes out at first and then slows down	Adjust finish height of impeller.
Inconsistent shot times	Adjust finish height of impeller. Change worn burrs.

15. Electrical Diagrams

Serial numbers up to 655

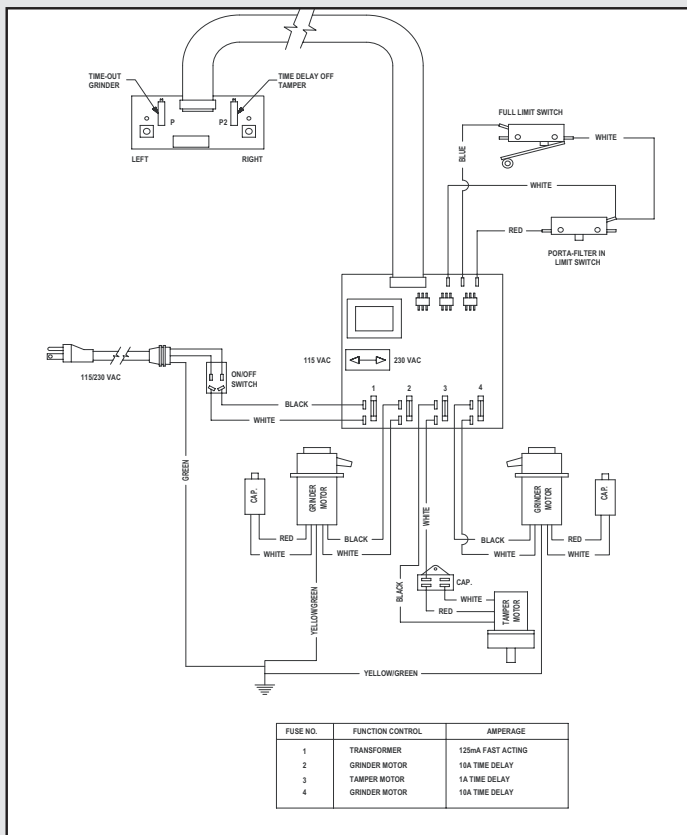

Serial numbers 655 and above

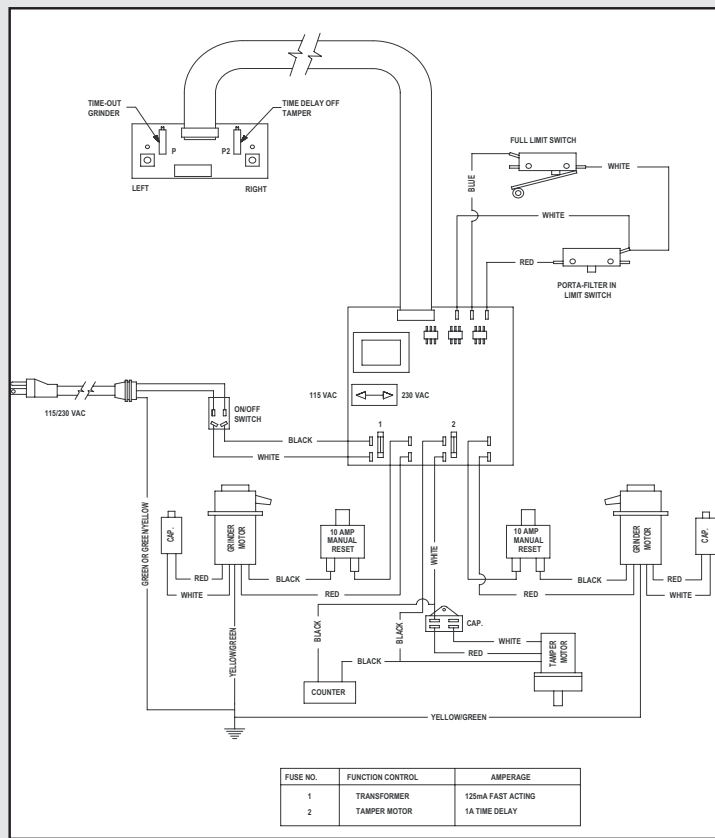

16. Cleaning Procedure

Change of grinding discs

1. Disconnect power supply from the coffee machine, stop bean flowing into the grinder and if necessary dismantle the grinder.
2. Release clamp [1] and remove it.

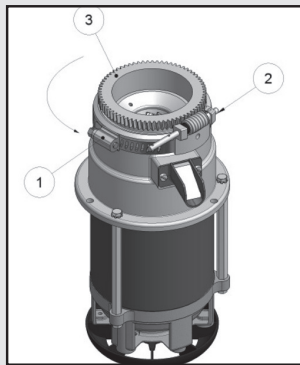

3. Turn stationary disc flange [3] anti-clockwise and take it off.
4. Unscrew the grinding discs (3 screws [4]) from the stationary- and rotary disc flanges. Do hold/block the

rotary disc flange [4a] with a plastic tool.

Cleaning

Use a brush to clean the surfaces of the flanges. Remove all coffee particles or dust from the thread and then lubricate it with slight film (spray) of Panolin TEF GREASE H1, Prod. 5975, food grade, NSF listed; www.panolin.com

5. Insert new grinding discs on the cleaned rotary- / stationary disc flanges and tighten screws carefully.
6. Re-install the stationary disc flange [5] clockwise (avoid touching of the grinding discs).
7. Connect power supply.
8. Calibrate grinder.

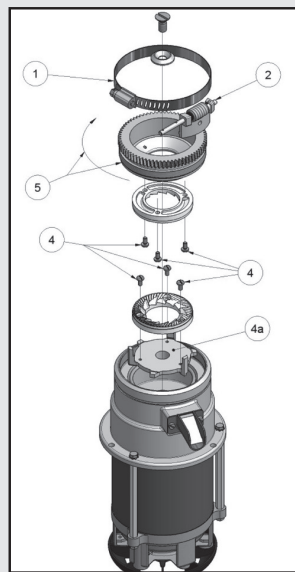

Important: All surfaces of the grinding discs as well as the flanges must be properly cleaned in order to ensure a perfect grinding.

17. Recycling

1) De-commissioning and demolition

Start by setting the main switch to the "0" or OFF position.

Disconnecting from the power outlet

Disconnect the SWIFT EPS_B from the electrical network by switching off the associated circuit breaker or circuit protection device. Remove the power supply cord from the power connection.

At this point, the machine may be removed from the bar, being very careful not to drop it or squash your fingers.

The machine is made out of various materials and therefore, if you do not intend to put it back in service, it must be taken to a special disposal company which will select the materials which can be recycled and discard the others. Current regulations make it illegal to discard such machine by leaving it on public grounds or on any private property.

Recycling notice: Warning for the protection of the environment.

Used Electrical and electronic waste contains hazardous but also valuable and scarce materials which should be recovered and recycled properly. We kindly ask that you contribute to the protection of the environment and natural resources by delivering used equipment to the relevant recycling locations if such locations are available in your country.

